

2026 VULCAN® S

PARTS DIAGRAM

Footrests

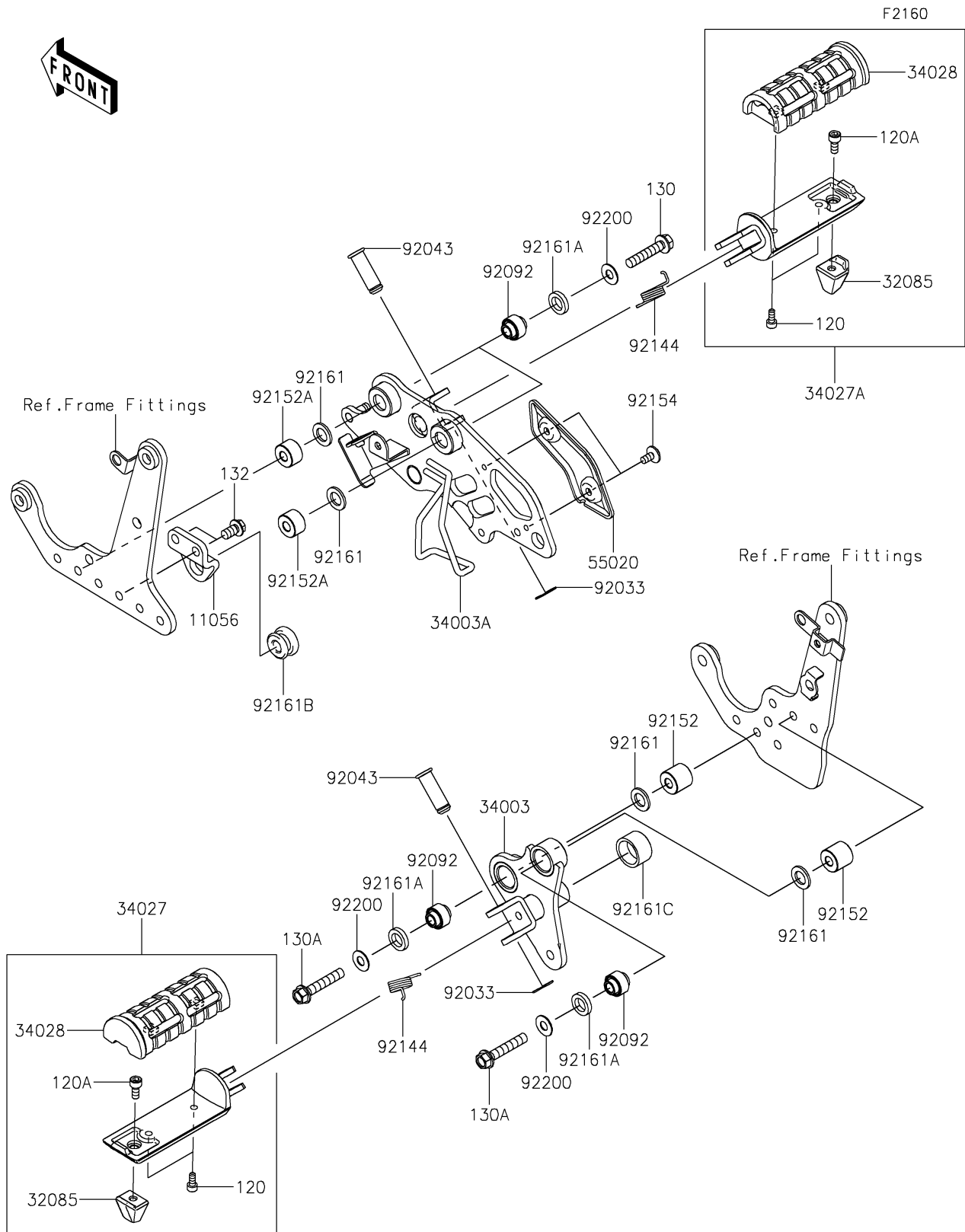

2026 VULCAN® S

PARTS LIST

Footrests

| ITEM NAME | PART NUMBER | QUANTITY |
|--|---------------|----------|
| BRACKET,STEP,FR,RH (Ref # 11056) | 11056-7031 | 1 |
| STOPPER,BANK SENSOR (Ref # 32085) | 32085-0770 | 2 |
| HOLDER-STEP,LH (Ref # 34003) | 34003-0141 | 1 |
| HOLDER-STEP,RH (Ref # 34003A) | 34003-0156 | 1 |
| STEP-ASSY,LH (Ref # 34027) | 34027-0012 | 1 |
| STEP-ASSY,RH (Ref # 34027A) | 34027-0013 | 1 |
| STEP,RUBBER (Ref # 34028) | 34028-0338 | 2 |
| GUARD,STEP HOLDER,RH (Ref # 55020) | 55020-1880 | 1 |
| RING-SNAP,10MM (Ref # 92033) | 92033-1166 | 2 |
| PIN,12X37 (Ref # 92043) | 92043-1358 | 2 |
| BUSHING-RUBBER,8.4X20X18 (Ref # 92092) | 92092-1018-SP | 4 |
| SPRING,STEP RETURN (Ref # 92144) | 92144-1126 | 2 |
| COLLAR,8.4X21X19 (Ref # 92152) | 92152-1952 | 2 |
| COLLAR,8.4X21X13 (Ref # 92152A) | 92152-1953 | 2 |
| BOLT,SOCKET,6X12 (Ref # 92154) | 92154-0951 | 2 |
| DAMPER,12.5X21X2 (Ref # 92161) | 92161-0943 | 4 |
| DAMPER,12.5X20X4 (Ref # 92161A) | 92161-0944 | 4 |
| DAMPER (Ref # 92161B) | 92161-1523 | 1 |
| DAMPER,21.5X27.5X16 (Ref # 92161C) | 92161-1702 | 1 |
| WASHER,8.5X19X1 (Ref # 92200) | 92200-1733 | 4 |
| BOLT-SOCKET,5X12 (Ref # 120) | 120CB0512 | 4 |
| BOLT-SOCKET,6X14 (Ref # 120A) | 120CB0614 | 2 |
| BOLT-FLANGED,8X40 (Ref # 130) | 130BB0840 | 2 |
| BOLT-FLANGED,8X45 (Ref # 130A) | 130BB0845 | 2 |
| BOLT-FLANGED-SMALL,8X14 (Ref # 132) | 132BB0814 | 2 |