

2026 RIDGE HVAC

PARTS DIAGRAM

Air Cleaner

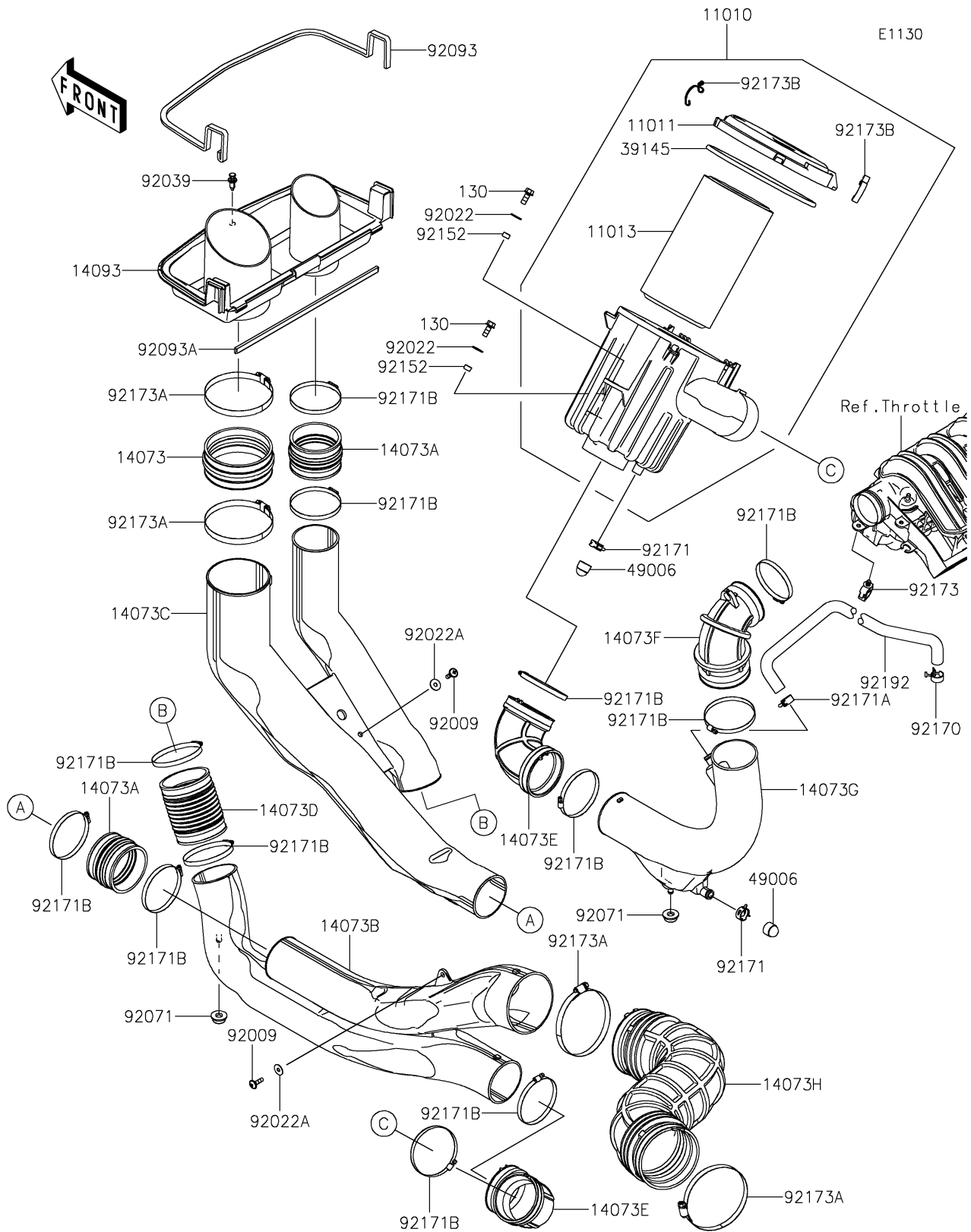

2026 RIDGE HVAC

PARTS LIST

Air Cleaner

ITEM NAME	PART NUMBER	QUANTITY
FILTER-ASSY-AIR (Ref # 11010)	11010-1850	1
CASE-AIR FILTER,UPP (Ref # 11011)	11011-0977	1
ELEMENT-AIR FILTER (Ref # 11013)	11013-0782	1
DUCT (Ref # 14073)	14073-0909	1
DUCT,A/F CASE (Ref # 14073A)	14073-0923	2
DUCT,CVT RR (Ref # 14073B)	14073-1905	1
DUCT,CVT FR (Ref # 14073C)	14073-1906	1
DUCT,CVT CNT (Ref # 14073D)	14073-1908	1
DUCT,A/C BOX (Ref # 14073E)	14073-1912	2
DUCT,THROTTLE (Ref # 14073F)	14073-1913	1
DUCT,CHAMBER (Ref # 14073G)	14073-1922	1
DUCT,CVT INTAKE (Ref # 14073H)	14073-1951	1
COVER,INTAKE (Ref # 14093)	14093-1446	1
TRIM-SEAL (Ref # 39145)	39145-0762	1
BOOT,DRAIN (Ref # 49006)	49006-3718	2
SCREW,6X22 (Ref # 92009)	92009-1441	2
WASHER,8.5X20X1.6 (Ref # 92022)	92022-1561	2
WASHER,PLAIN,6.5X20X1 (Ref # 92022A)	92022-165	2
RIVET (Ref # 92039)	92039-0776	1
GROMMET (Ref # 92071)	92071-0829	2
SEAL (Ref # 92093)	92093-0792	1
SEAL (Ref # 92093A)	92093-0793	1
COLLAR,8.8X12.3X6.9 (Ref # 92152)	92152-1853	2
CLAMP (Ref # 92170)	92170-1060	1
CLAMP (Ref # 92171)	92171-0329	2
CLAMP (Ref # 92171A)	92171-1277	1
CLAMP (Ref # 92171B)	92171-1383	12
CLAMP (Ref # 92173)	92173-0861	1
CLAMP,130MM (Ref # 92173A)	92173-1938	4

2026 RIDGE HVAC

PARTS LIST

Air Cleaner

ITEM NAME	PART NUMBER	QUANTITY
CLAMP,AIR FILTER CASE (Ref # 92173B)	92173-2023	2
TUBE,BREATHING (Ref # 92192)	92192-2651	1
BOLT-FLANGED,8X20 (Ref # 130)	130BA0820	2