

2026 Z H2 SE ABS

PARTS DIAGRAM

Crankcase

E1411

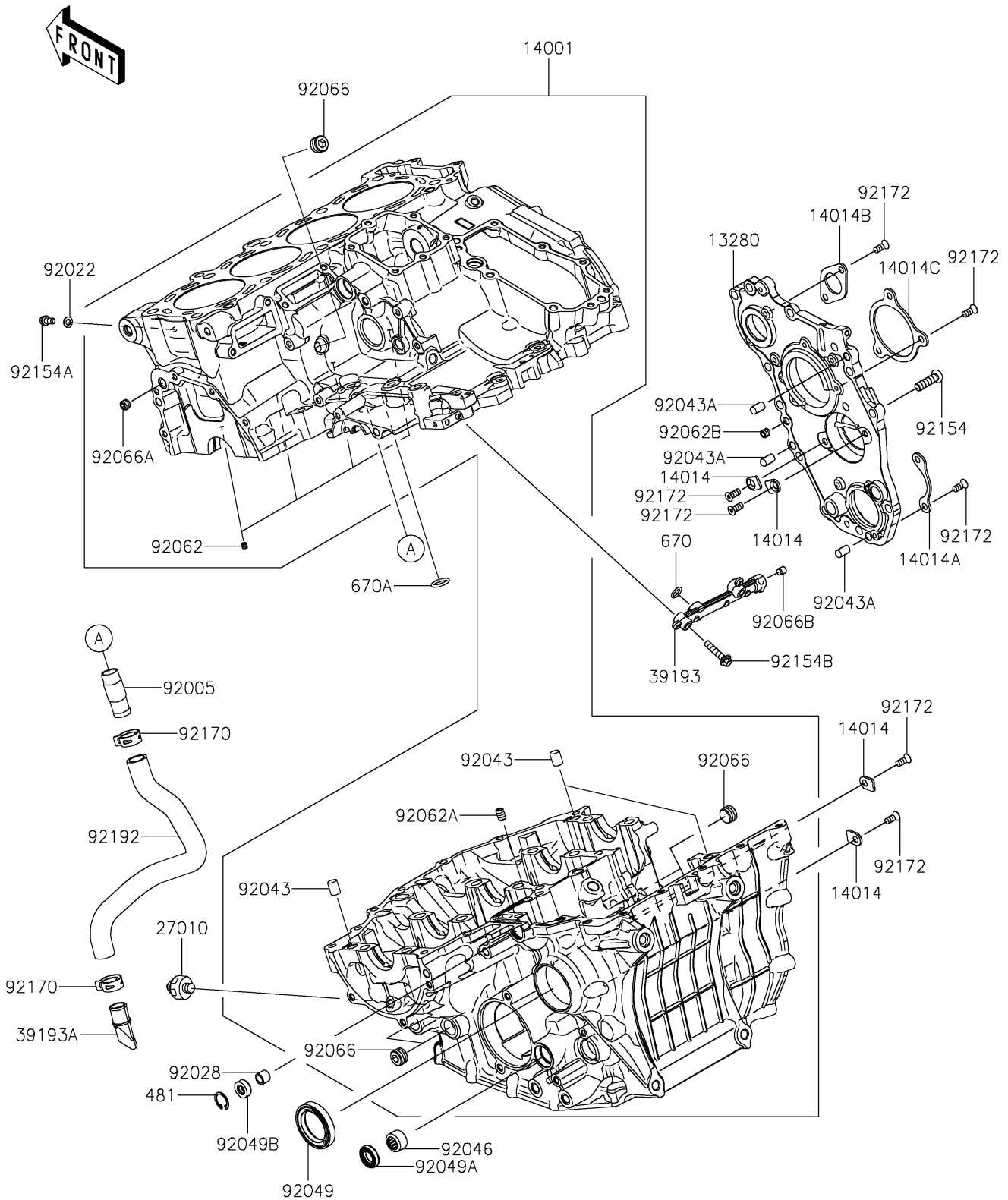

2026 Z H2 SE ABS

PARTS LIST

Crankcase

ITEM NAME

PART NUMBER

QUANTITY
