

2024 KX™ 250 50th ANNIVERSARY EDITION

PARTS DIAGRAM

Chassis Electrical Equipment

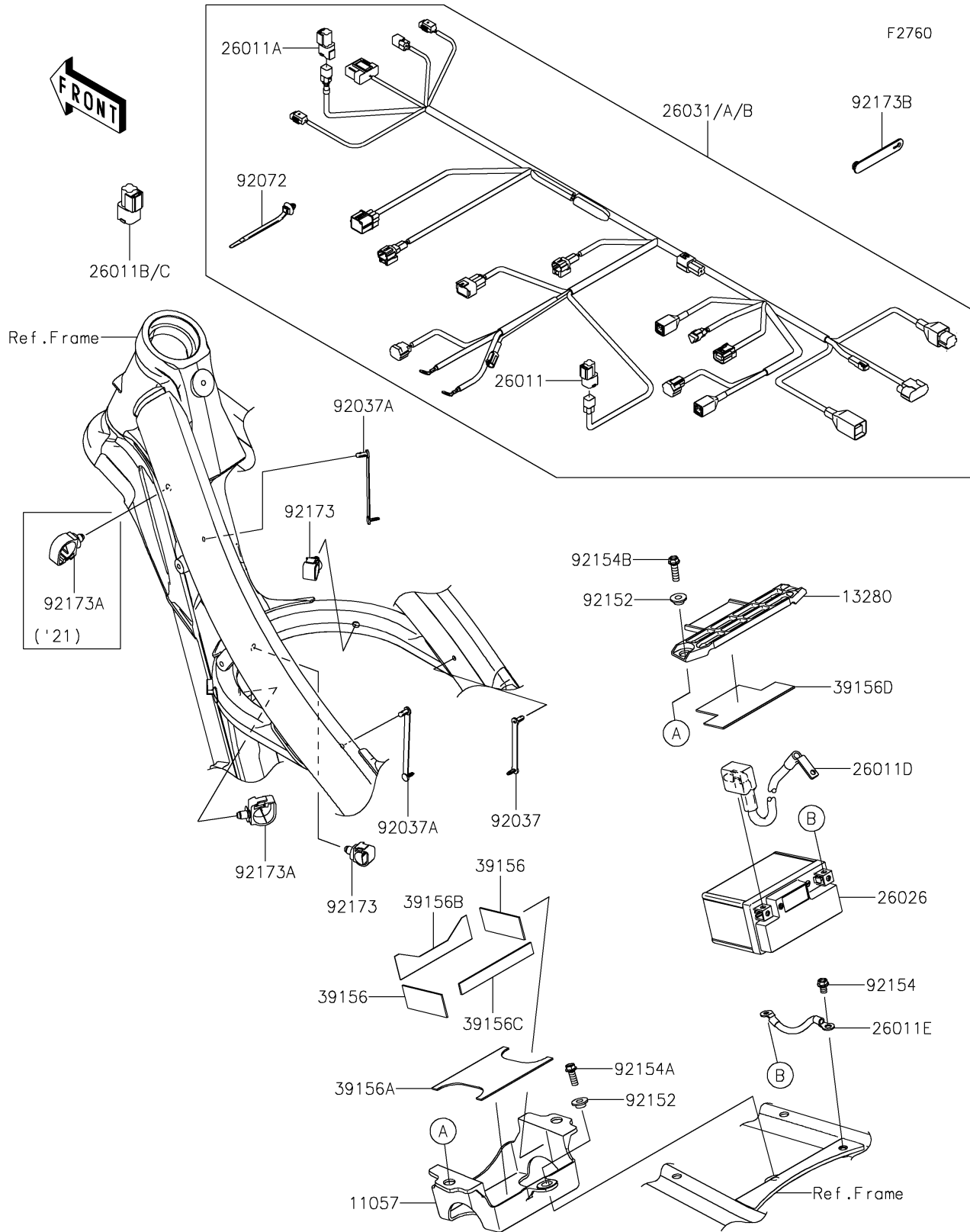

2024 KX™ 250 50th ANNIVERSARY EDITION



PARTS LIST

Chassis Electrical Equipment

ITEM NAME	PART NUMBER	QUANTITY
-----------	-------------	----------
