

2009 Vulcan® 2000 Classic LT

PARTS DIAGRAM

Oil Pump

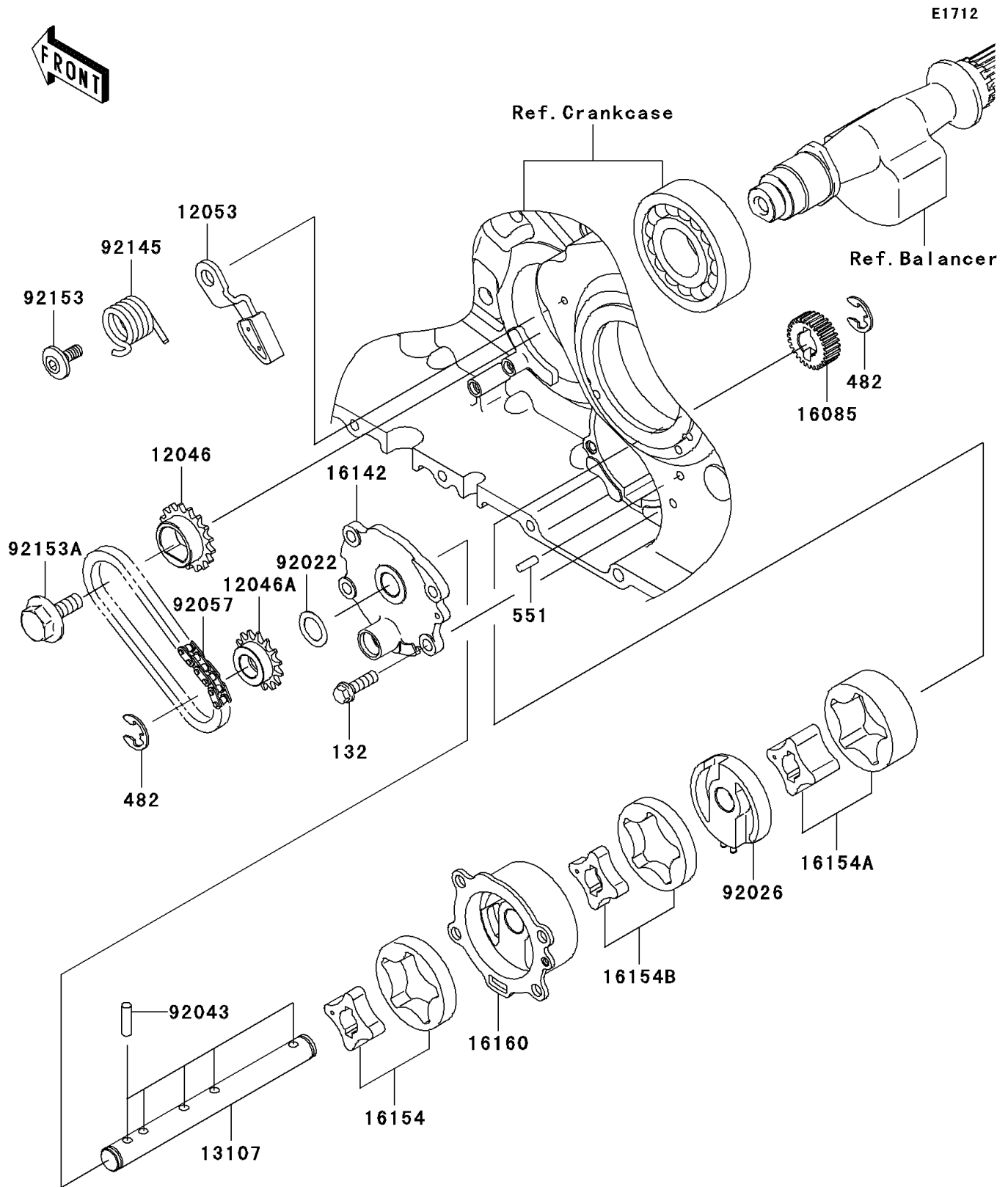

2009 Vulcan® 2000 Classic LT

PARTS LIST

Oil Pump

ITEM NAME	PART NUMBER	QUANTITY
-----------	-------------	----------
