

1999 Vulcan 800 Classic

PARTS DIAGRAM

Rear Wheel/Chain

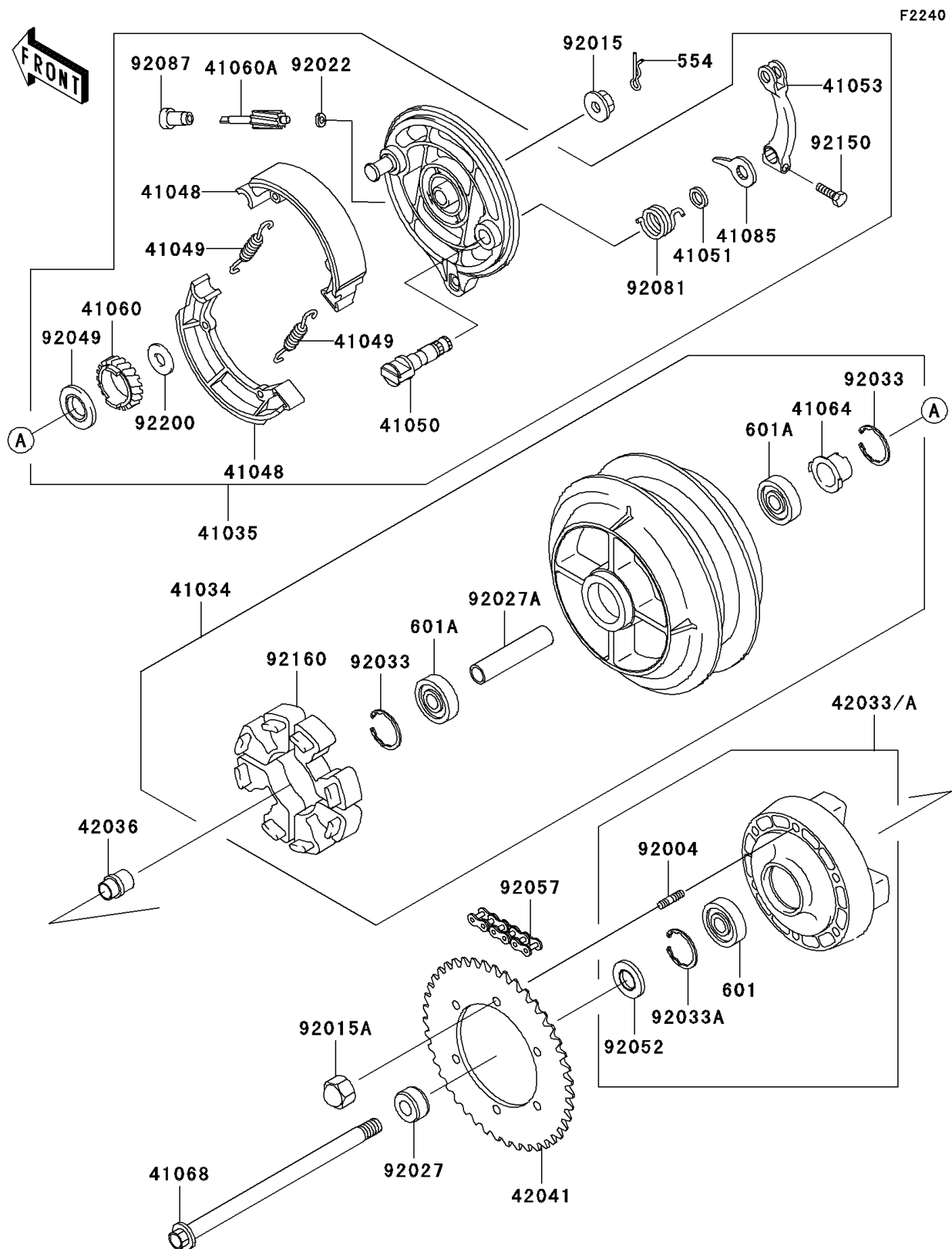

1999 Vulcan 800 Classic

PARTS LIST

Rear Wheel/Chain

ITEM NAME	PART NUMBER	QUANTITY
-----------	-------------	----------
