

2020 KX™ 450

PARTS DIAGRAM

Chassis Electrical Equipment

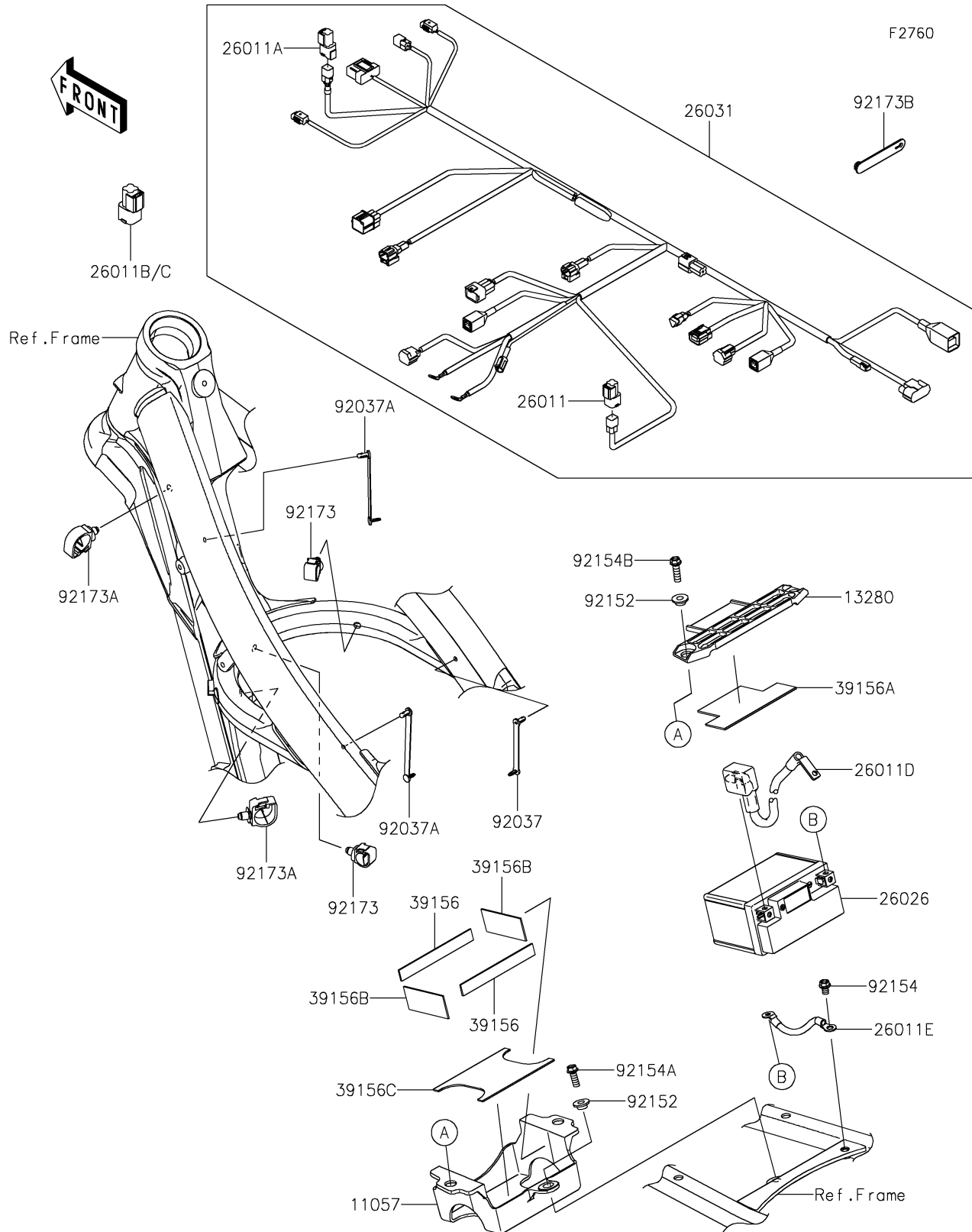

2020 KX™ 450

PARTS LIST

Chassis Electrical Equipment

ITEM NAME

PART NUMBER

QUANTITY
