

# 1999 Vulcan 1500

## PARTS DIAGRAM

### Cylinder/Piston(s)

E1120

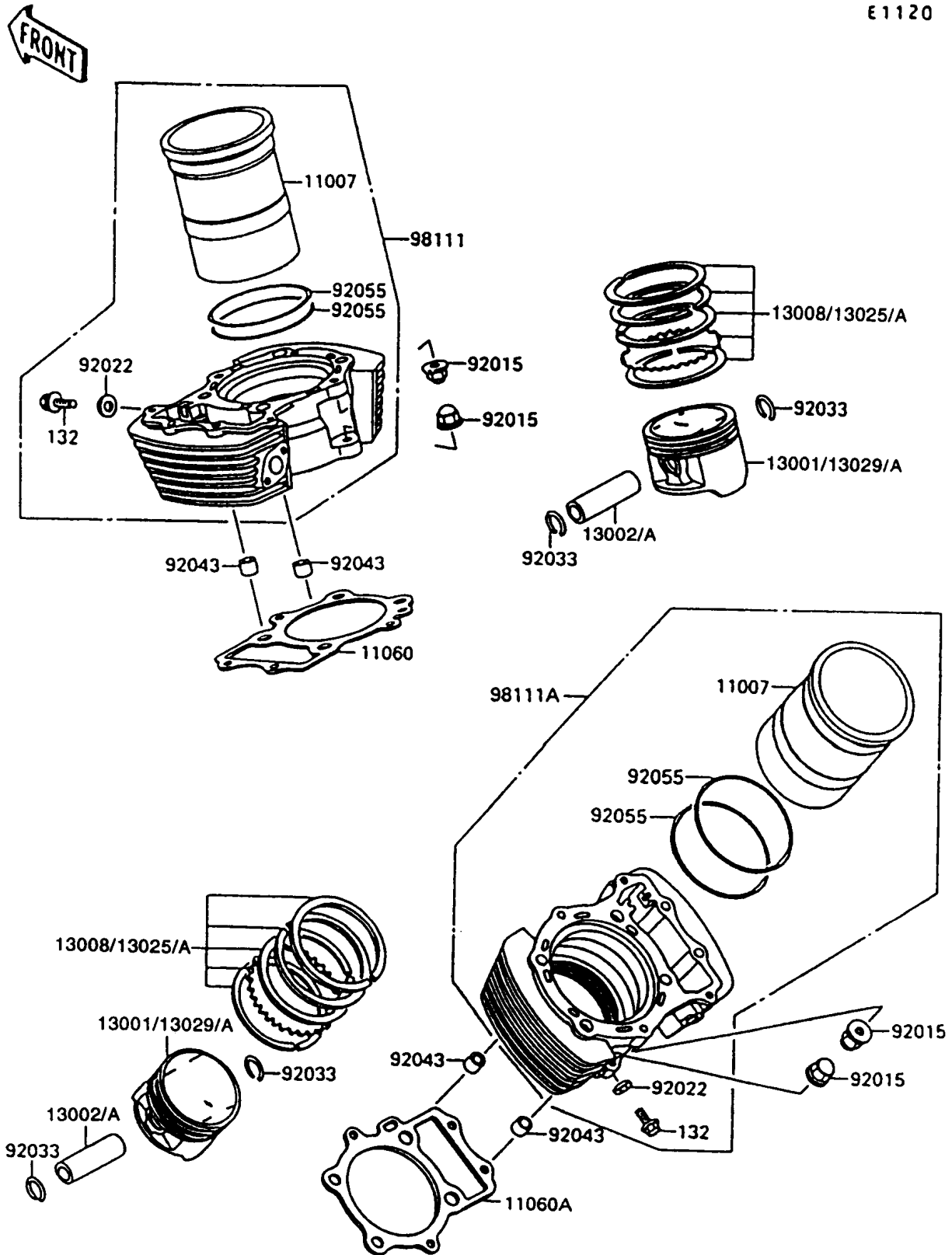

# 1999 Vulcan 1500

## PARTS LIST

Cylinder/Piston(s)

**ITEM NAME**

**PART NUMBER**

**QUANTITY**

---