

2015 MULE PRO-FXT™ EPS

PARTS DIAGRAM

Labels

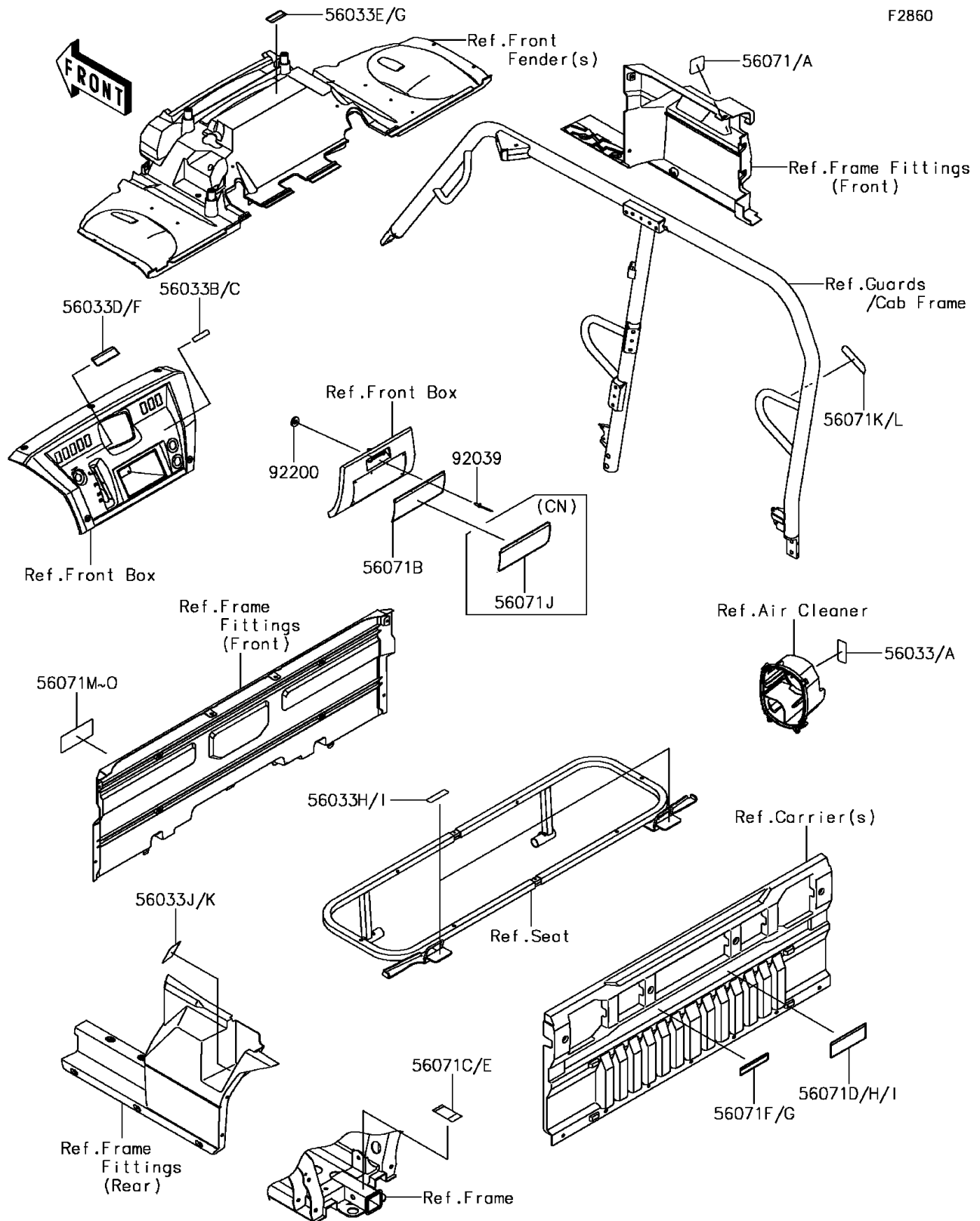

2015 MULE PRO-FXT™ EPS

PARTS LIST

Labels

ITEM NAME	PART NUMBER	QUANTITY
LABEL-MANUAL,AIR CLEANER (Ref # 56033)	56033-0724	1
LABEL-MANUAL,AIR CLEANER (Ref # 56033A)	56033-0731	1
LABEL-MANUAL,DC OUTLET (Ref # 56033B)	56033-0814	1
LABEL-MANUAL,DC OUTLET (Ref # 56033C)	56033-0816	1
LABEL-MANUAL,SHIFT NOTICE (Ref # 56033D)	56033-0822	1
LABEL-MANUAL,FRONT HOOD (Ref # 56033E)	56033-0825	1
LABEL-MANUAL,SHIFT NOTICE (Ref # 56033F)	56033-0826	1
LABEL-MANUAL,FRONT HOOD (Ref # 56033G)	56033-0827	1
LABEL-MANUAL,REAR SEAT (Ref # 56033H)	56033-0829	2
LABEL-MANUAL,REAR SEAT (Ref # 56033I)	56033-0830	2
LABEL-MANUAL,DRIVE BELT (Ref # 56033J)	56033-0831	1
LABEL-MANUAL,DRIVE BELT (Ref # 56033K)	56033-0832	1
LABEL-WARNING,GASOLINE (Ref # 56071)	56071-0292	1
LABEL-WARNING,GASOLINE (Ref # 56071A)	56071-0293	1
LABEL-WARNING,GENERAL (Ref # 56071B)	56071-0433	1
LABEL-WARNING,TRAILER HITCH (Ref # 56071C)	56071-0436	1
LABEL-WARNING,CARGO CAPA. (Ref # 56071D)	56071-0437	1
LABEL-WARNING,TRAILER HITCH (Ref # 56071E)	56071-0439	1
LABEL-WARNING,SCREEN OPERATION (Ref # 56071F)	56071-0471	1
LABEL-WARNING,SCREEN OPERATION (Ref # 56071G)	56071-0472	1
LABEL-WARNING,CARGO CAPA. (Ref # 56071H)	56071-0478	1
LABEL-WARNING,CARGO CAPA. (Ref # 56071I)	56071-0480	1
LABEL-WARNING,GENERAL (Ref # 56071J)	56071-0490	1
LABEL-WARNING,BED OPERATION (Ref # 56071K)	56071-0494	2
LABEL-WARNING,BED OPERATION (Ref # 56071L)	56071-0495	2
LABEL-WARNING,TIRE&LOAD (Ref # 56071M)	56071-0679	1
LABEL-WARNING,TIRE&LOAD (Ref # 56071N)	56071-0681	1
LABEL-WARNING,TIRE&LOAD (Ref # 56071O)	56071-0683	1
RIVET,3.2X8 (Ref # 92039)	92039-3763	6

2015 MULE PRO-FXT™ EPS

PARTS LIST

Labels

ITEM NAME	PART NUMBER	QUANTITY
WASHER,3.5X8X1 (Ref # 92200)	92200-1251	6