

2009 Vulcan® 1700 Voyager®

PARTS DIAGRAM

Fuel Tank

F2410

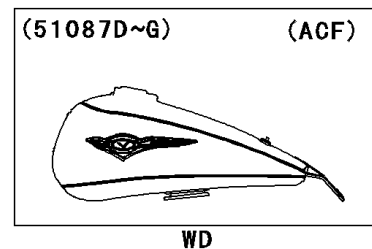
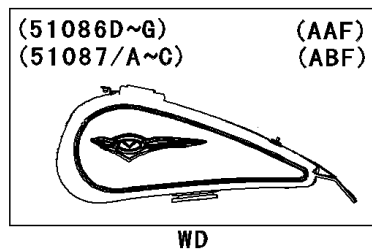
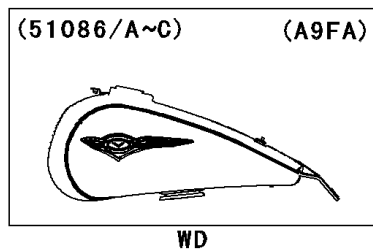
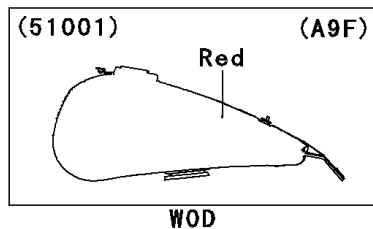
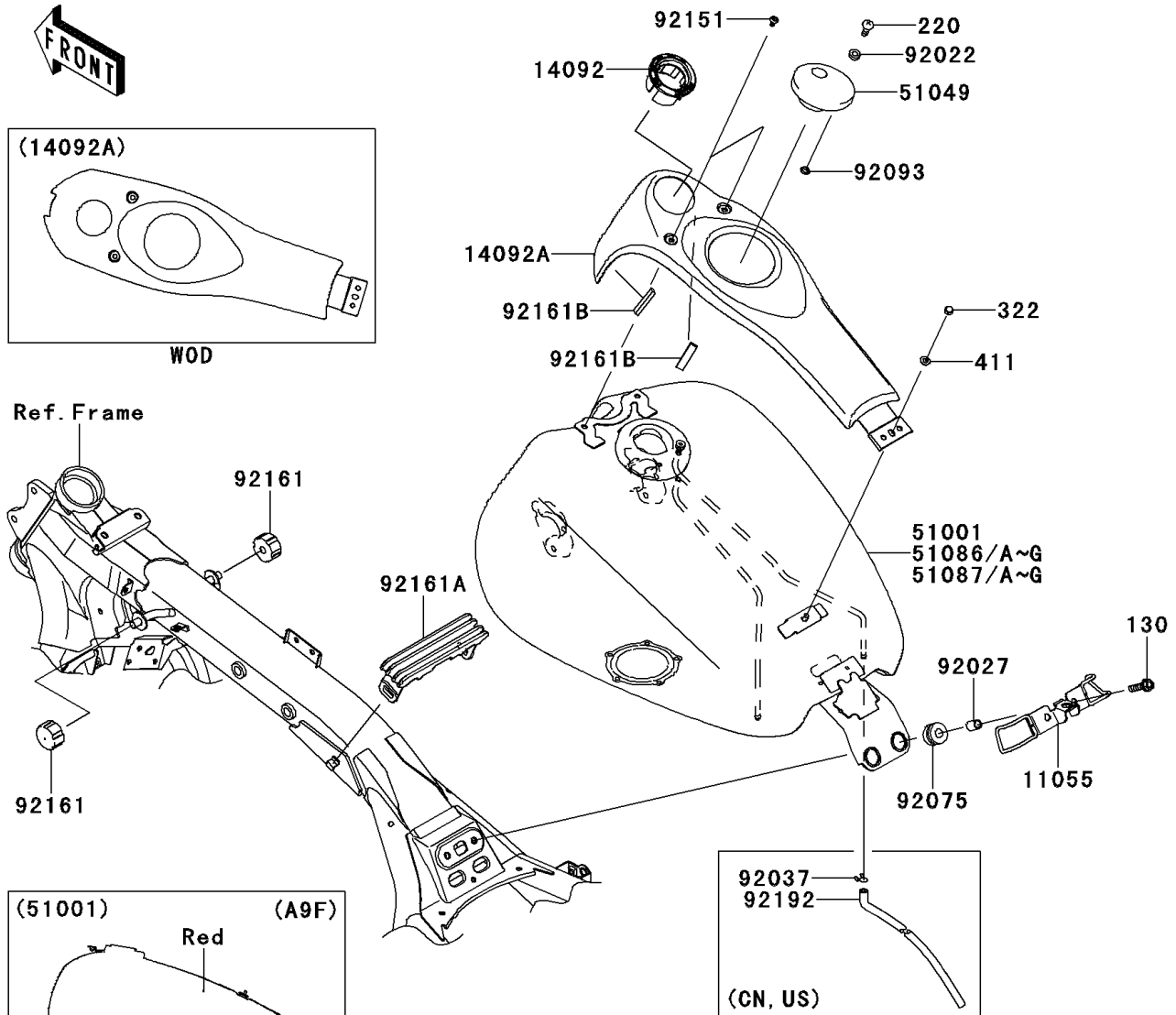

(51086/C)	Blue/Black
(51086A/B)	Titanium/Black

(51086D/E)	Black/Red
(51086F/G)	Blue/Gray
(51087/B)	Ebony/Gray
(51087A/C)	Blue/Silver

(51087D/F)	Black/Graystone
(51087E/G)	White/Beige

2009 Vulcan® 1700 Voyager®

PARTS LIST

Fuel Tank

Kawasaki
Let the Good Times Roll®

ITEM NAME

PART NUMBER

QUANTITY
