

1988 X2

PARTS DIAGRAM

Crankshaft/Piston(s)

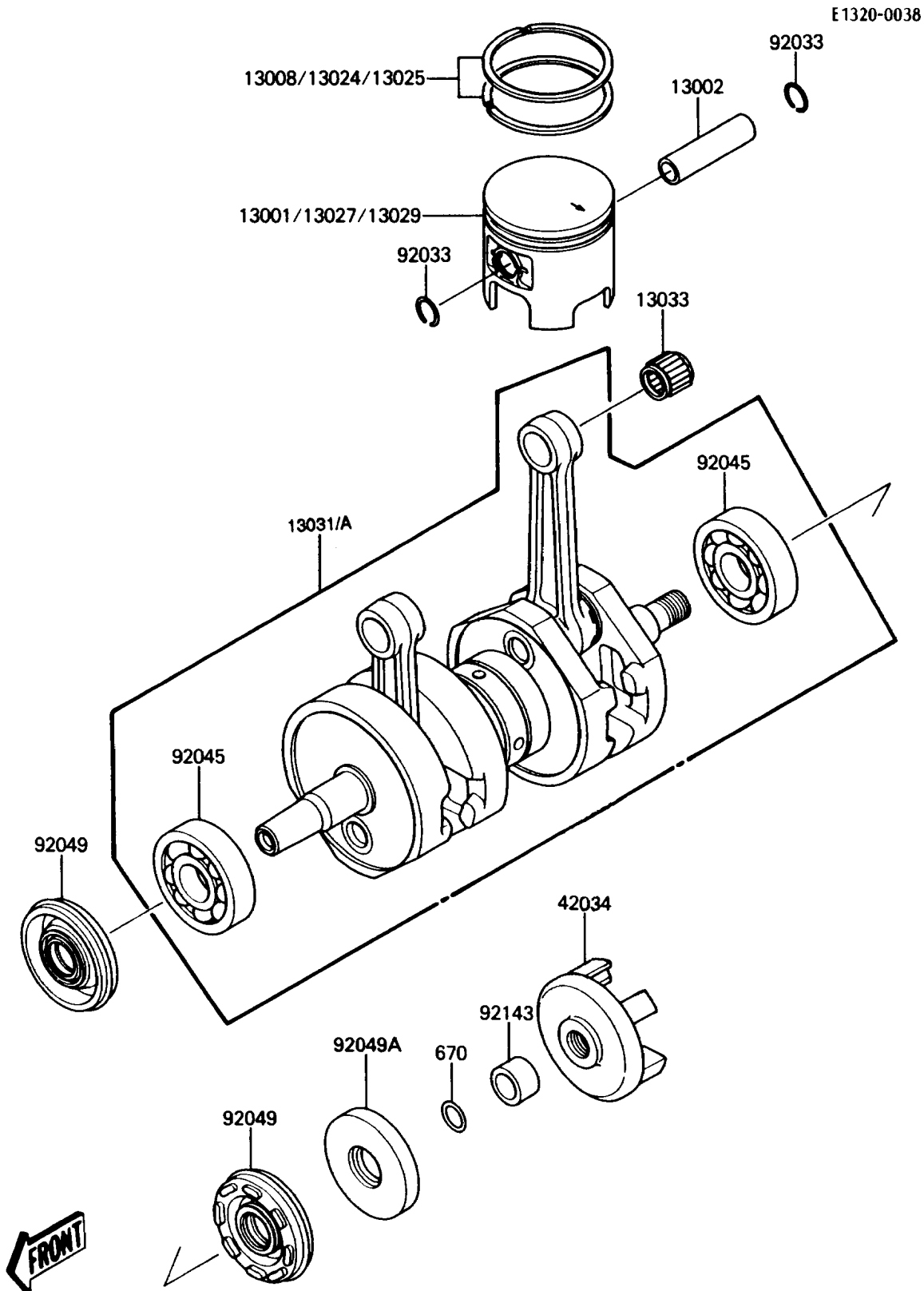

1988 X2

PARTS LIST

Crankshaft/Piston(s)

ITEM NAME

PART NUMBER

QUANTITY
