

2011 NINJA® 650R PARTS DIAGRAM

Chassis Electrical Equipment

F2760

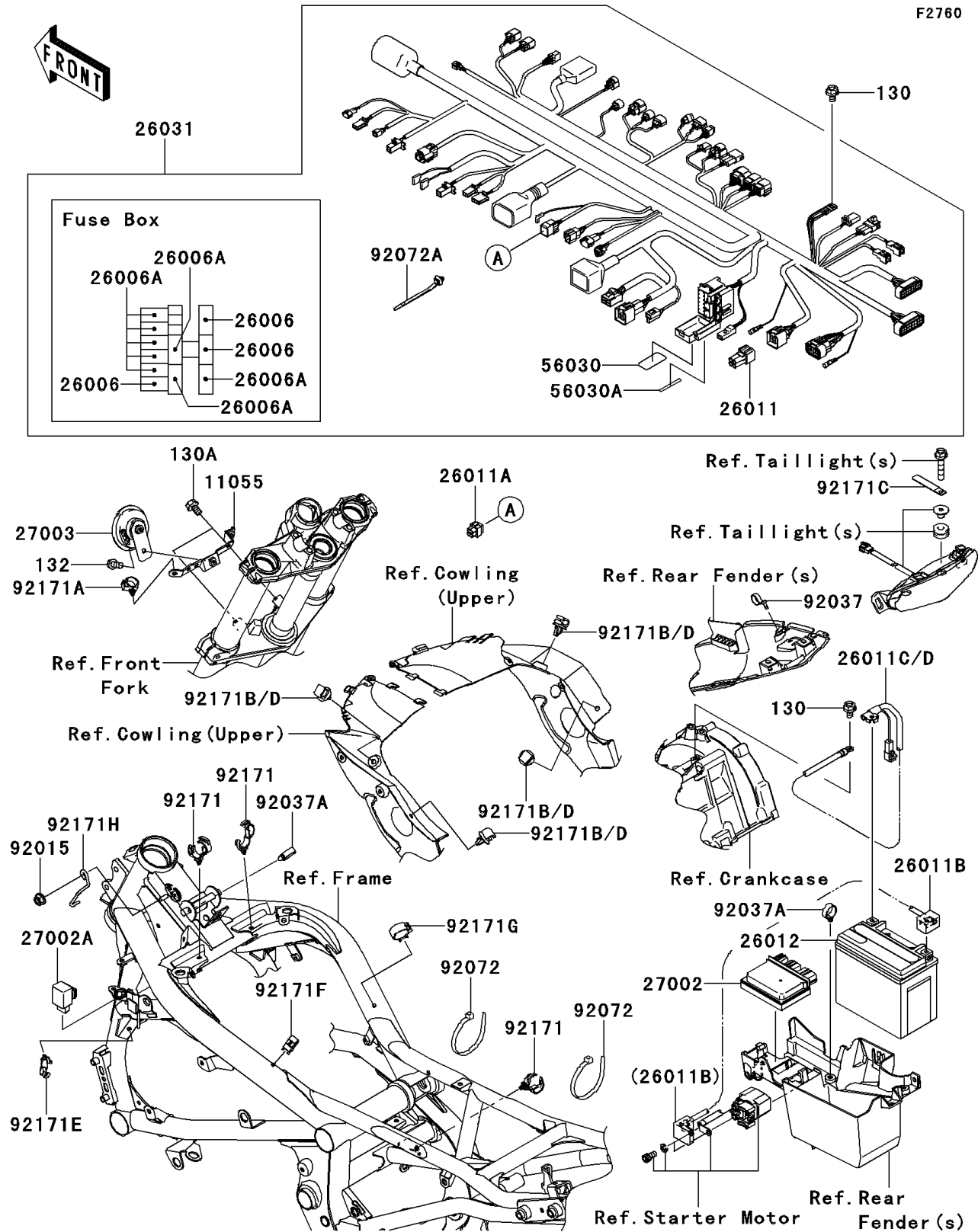

2011 NINJA® 650R PARTS LIST

Chassis Electrical Equipment

| ITEM NAME | PART NUMBER | QUANTITY |
|---|-------------|----------|
| BOLT-FLANGED,6X12 (Ref # 130) | 130BA0612 | 1 |
| BOLT-FLANGED,6X10 (Ref # 130A) | 130BB0610 | 1 |
| BOLT-FLANGED-SMALL,6X12 (Ref # 132) | 132BB0612 | 1 |
| BRACKET,HORN,FRONT FORK (Ref # 11055) | 11055-1334 | 1 |
| FUSE,MINI BLADE,15A,BLUE (Ref # 26006) | 26006-0001 | 1 |
| FUSE,MINI BLADE,10A,RED (Ref # 26006A) | 26006-1078 | 1 |
| WIRE-LEAD (Ref # 26011) | 26011-0082 | 1 |
| WIRE-LEAD,SENSOR CONNECTOR (Ref # 26011A) | 26011-0101 | 1 |
| WIRE-LEAD,BATTERY(+) (Ref # 26011B) | 26011-0247 | 1 |
| WIRE-LEAD,BATTERY(-) (Ref # 26011D) | 26011-0300 | 1 |
| BATTERY,FTX12-BS,12V 10AH (Ref # 26012) | 26012-0109 | 1 |
| HARNESS,MAIN (Ref # 26031) | 26031-0705 | 1 |
| RELAY-ASSY (Ref # 27002) | 27002-0007 | 1 |
| RELAY-ASSY,SIGNAL LAMP (Ref # 27002A) | 27002-1097 | 1 |
| HORN (Ref # 27003) | 27003-0065 | 1 |
| LABEL,FUSE BOX (Ref # 56030) | 56030-0046 | 1 |
| LABEL,FUSE BOX (Ref # 56030A) | 56030-0098 | 1 |
| NUT,FLANGED,6MM,BLACK (Ref # 92015) | 92015-1233 | 1 |
| CLAMP,SPEED,L=58 (Ref # 92037) | 92037-1163 | 1 |
| CLAMP,HOSE (Ref # 92037A) | 92037-1827 | 1 |
| BAND,L=365 (Ref # 92072) | 92072-1197 | 1 |
| BAND (Ref # 92072A) | 92072-1414 | 1 |
| CLAMP,DIA=20 (Ref # 92171) | 92171-0069 | 1 |
| CLAMP,BRAKE HOSE (Ref # 92171A) | 92171-0316 | 1 |
| CLAMP (Ref # 92171C) | 92171-0652 | 1 |
| CLAMP (Ref # 92171D) | 92171-0834 | 1 |
| CLAMP,DIA=13 (Ref # 92171E) | 92171-1415 | 1 |
| CLAMP,DIA=15 (Ref # 92171F) | 92171-1424 | 1 |
| CLAMP,DIA=25 (Ref # 92171G) | 92171-1559 | 1 |

2011 NINJA® 650R PARTS LIST

Chassis Electrical Equipment

| ITEM NAME | PART NUMBER | QUANTITY |
|----------------------|-------------|----------|
| CLAMP (Ref # 92171H) | 92171-1897 | 1 |