

1996 GPZ 1100 ABS PARTS DIAGRAM

Chassis Electrical Equipment

F2760

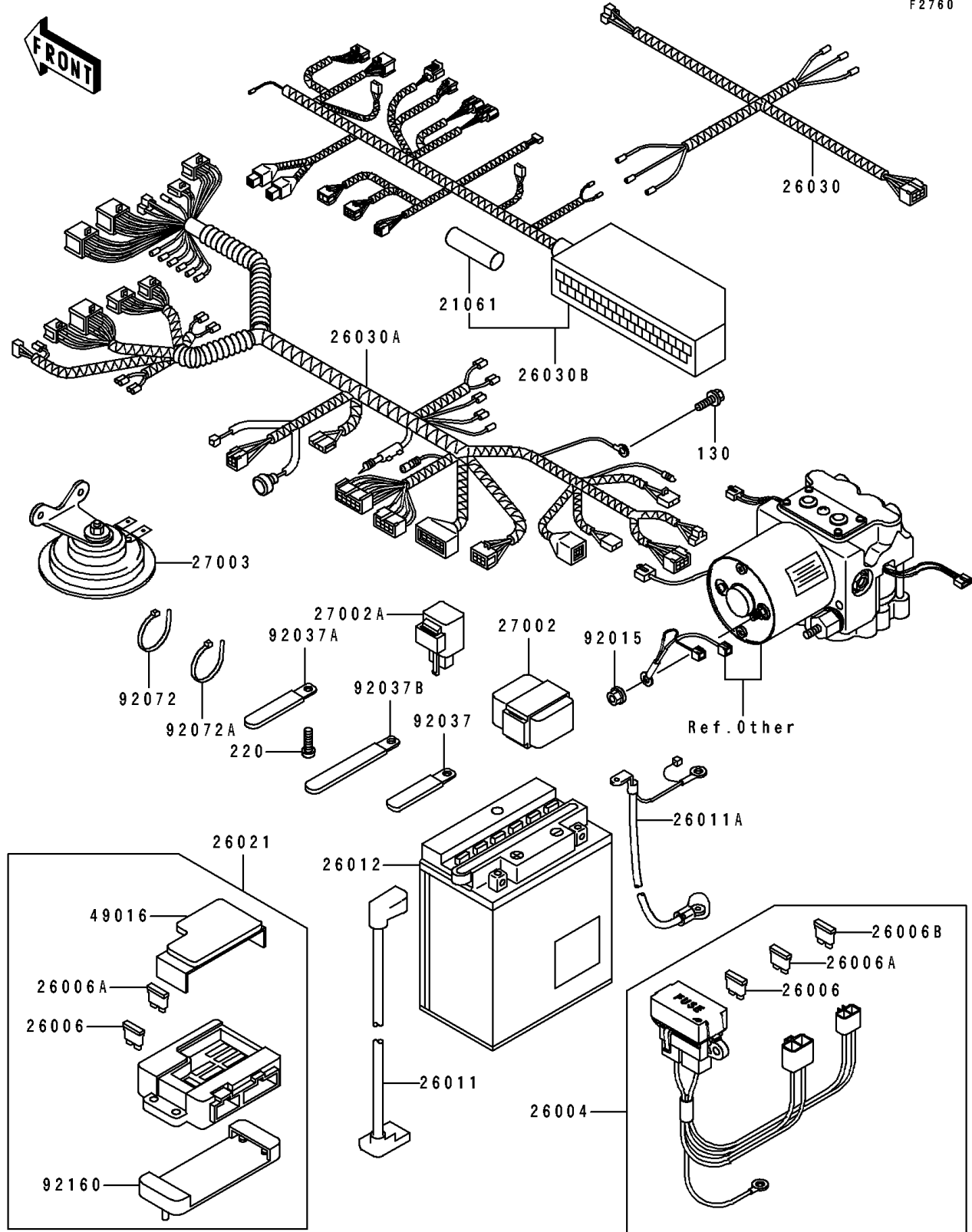

1996 GPZ 1100 ABS PARTS LIST

Chassis Electrical Equipment

ITEM NAME	PART NUMBER	QUANTITY
RECTIFIER (Ref # 21061)	21061-1060	1
FUSE-ASSY (Ref # 26004)	26004-1103	1
FUSE,30A-G (Ref # 26006)	26006-1067	3
FUSE,10A-R (Ref # 26006A)	26006-1068	9
FUSE,15A-B (Ref # 26006B)	26006-1069	2
WIRE-LEAD,BATTERY(+) (Ref # 26011)	26011-1615	1
WIRE-LEAD,BATTERY(-) (Ref # 26011A)	26011-1630	1
BATTERY,YTX14-BS,12V 12AH (Ref # 26012)	26012-1279	1
JUNCTION BOX (Ref # 26021)	26021-1096	1
HARNESS,FR (Ref # 26030)	26030-1340	1
HARNESS,MAIN (Ref # 26030A)	26030-1342	1
HARNESS,A.B.S. (Ref # 26030B)	26030-1399	1
RELAY-ASSY (Ref # 27002)	27002-1065	1
RELAY-ASSY,SIGNAL LAMP (Ref # 27002A)	27002-1092	1
HORN (Ref # 27003)	27003-1385	1
COVER-SEAL,FUSE (Ref # 49016)	49016-1177	1
NUT,FLANGED,5MM (Ref # 92015)	92015-1656	1
CLAMP,WIRING HARNESS (Ref # 92037)	92037-1069	5
CLAMP,WIRING HARNESS (Ref # 92037A)	92037-1539	1
CLAMP (Ref # 92037B)	92037-1993	1
BAND,L=185 (Ref # 92072)	92072-1195	13
BAND,L=365 (Ref # 92072A)	92072-1197	3
DAMPER,JUNCTION BOX (Ref # 92160)	92160-1650	1
BOLT-FLANGED (Ref # 130)	130J0612	1
SCREW-PAN-CROS (Ref # 220)	220C0510	1