

1999 ZRX1100 PARTS DIAGRAM

Chassis Electrical Equipment

F2760

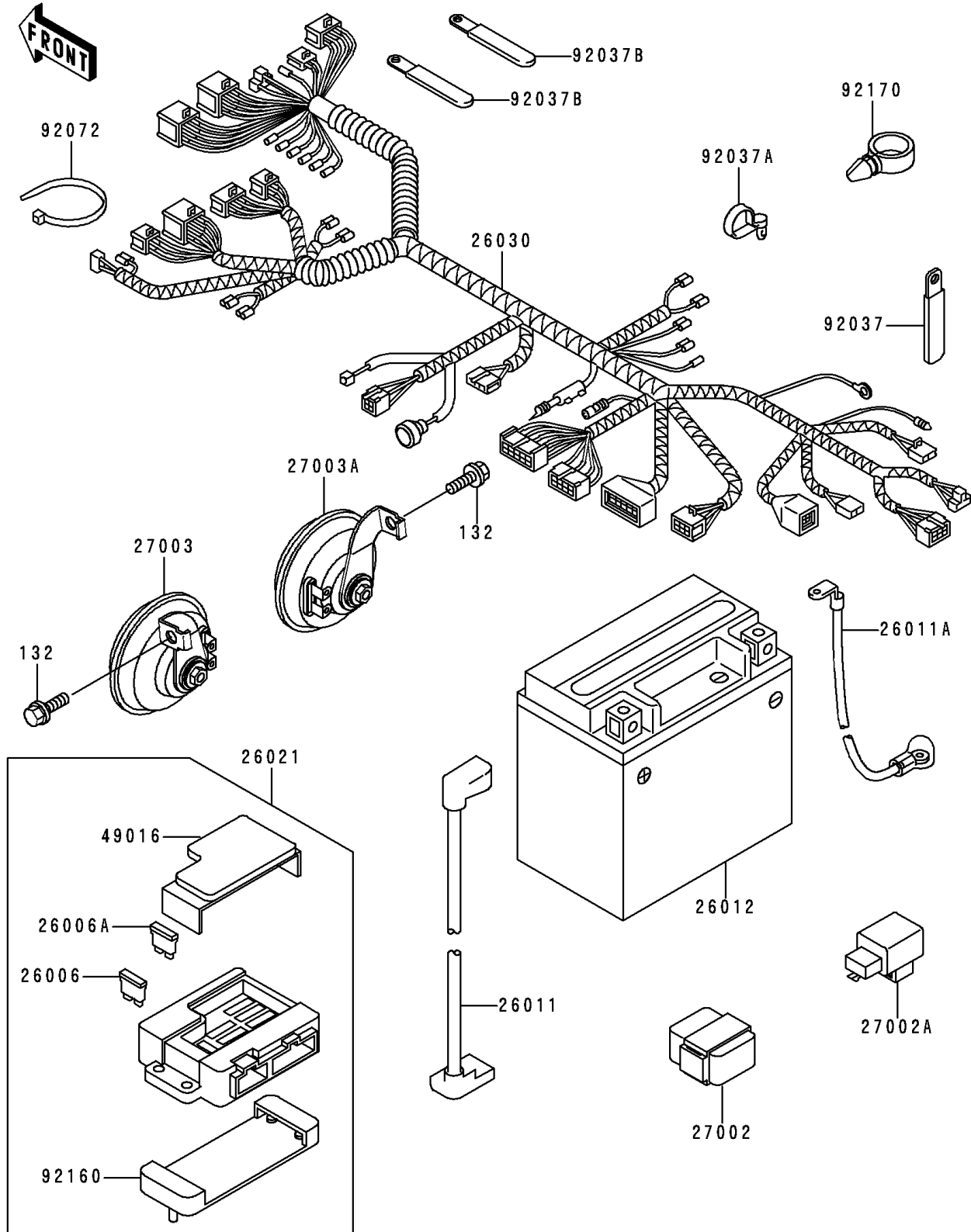

1999 ZRX1100 PARTS LIST

Chassis Electrical Equipment

ITEM NAME	PART NUMBER	QUANTITY
BOLT-FLANGED-SMALL,8X12 (Ref # 132)	132J0812	2
FUSE,30A-G (Ref # 26006)	26006-1067	1
FUSE,10A-R (Ref # 26006A)	26006-1068	8
WIRE-LEAD,BATTERY(+) (Ref # 26011)	26011-1652	1
WIRE-LEAD,BATTERY(-) (Ref # 26011A)	26011-1653	1
BATTERY,YTX14-BS,12V 12AH (Ref # 26012)	26012-1334	1
JUNCTION BOX (Ref # 26021)	26021-1096	1
HARNESS,MAIN (Ref # 26030)	26030-1629	1
RELAY-ASSY,HEAD LAMP (Ref # 27002)	27002-1078	1
RELAY-ASSY,TURN SIGNAL (Ref # 27002A)	27002-1101	1
HORN,LH (Ref # 27003)	27003-1402	1
HORN,RH (Ref # 27003A)	27003-1403	1
COVER-SEAL,FUSE (Ref # 49016)	49016-1177	1
CLAMP,WIRING HARNESS,L=60 (Ref # 92037)	92037-1069	2
CLAMP,SPEED,L=80.5 (Ref # 92037A)	92037-1903	2
CLAMP (Ref # 92037B)	92037-1993	2
BAND,L=250 (Ref # 92072)	92072-1237	12
DAMPER,JUNCTION BOX (Ref # 92160)	92160-1650	1
CLAMP (Ref # 92170)	92170-1067	1