

## 1999 Vulcan 1500 Drifter PARTS DIAGRAM

Battery Case

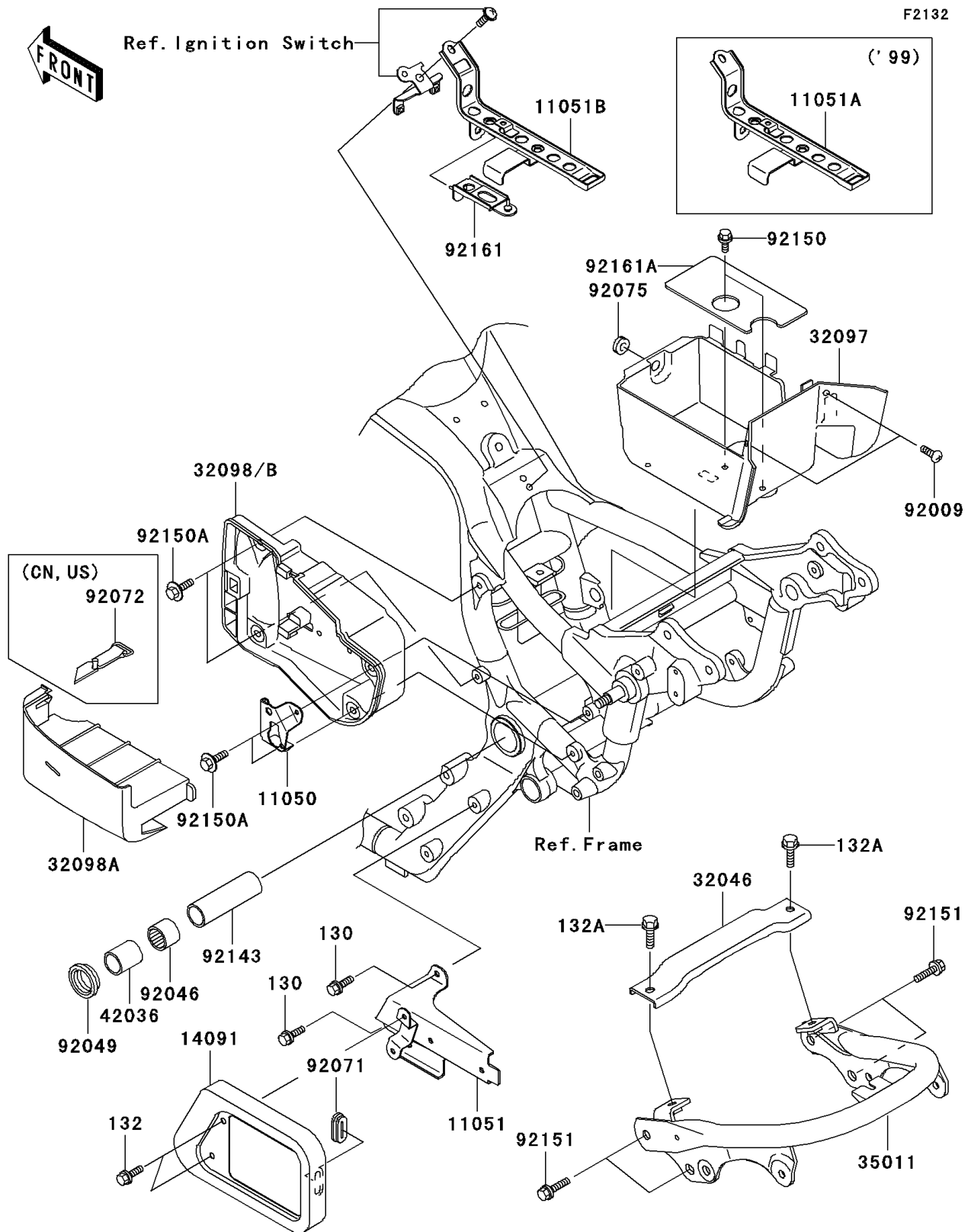

## 1999 Vulcan 1500 Drifter PARTS LIST

### Battery Case

ITEM NAME	PART NUMBER	QUANTITY
BOLT-FLANGED (Ref # 130)	130J0612	1
BOLT-FLANGED-SMALL (Ref # 132)	132E0612	1
BOLT-FLANGED-SMALL,8X16 (Ref # 132A)	132J0816	1
BRACKET,SIDE COVER LOCK (Ref # 11050)	11050-1958	1
BRACKET,REGULATOR (Ref # 11051)	11051-1163	1
BRACKET,BATTERY BAND (Ref # 11051A)	11051-1798	1
COVER,REGULATOR (Ref # 14091)	14091-1079	1
BRACKET-SEAT (Ref # 32046)	32046-1478	1
CASE-BATTERY (Ref # 32097)	32097-1175	1
CASE-TOOL,COVER (Ref # 32098A)	32098-1126	1
STAY,SEAT (Ref # 35011)	35011-1968	1
SLEEVE,L=45 (Ref # 42036)	42036-1330	1
SCREW,6X10 (Ref # 92009)	92009-1402	1
BEARING-NEEDLE,BM2824 (Ref # 92046)	92046-1202	1
SEAL-OIL (Ref # 92049)	92049-1181	1
GROMMET (Ref # 92071)	92071-1187	1
DAMPER (Ref # 92075)	92075-1067	1
COLLAR,20.2X27X90 (Ref # 92143)	92143-1878	1
BOLT,6X14 (Ref # 92150)	92150-1133	1
BOLT,6X16 (Ref # 92150A)	92150-1198	1
BOLT,FLANGED,10X18 (Ref # 92151)	92151-1440	1
DAMPER,BATTERY BAND (Ref # 92161)	92161-1096	1
DAMPER,BATTERY (Ref # 92161A)	92161-1097	1
CASE-TOOL (Ref # 32098)	32098-1125	1
CASE-TOOL (Ref # 32098B)	32098-1127	1
BAND,L=470 (Ref # 92072)	92072-1331	1