

# 2008 Vulcan® 1600 Classic PARTS DIAGRAM

Fuel Tank(4/4)

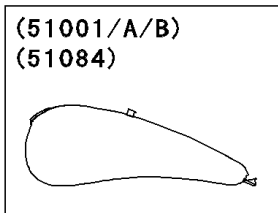
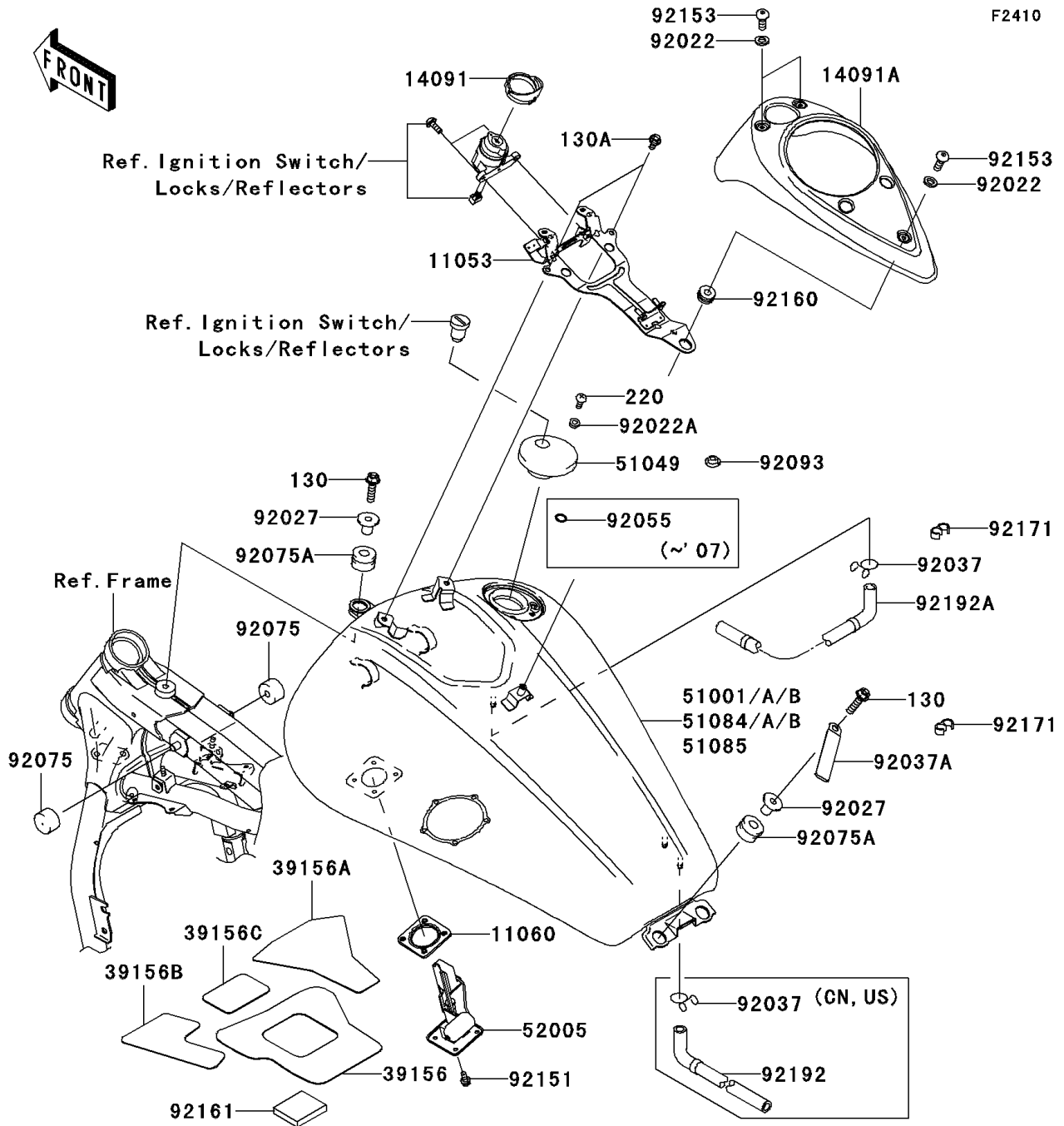

WOD

(51001/A)	Ebony
(51084)	
(51001B)	Black

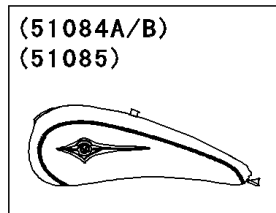

WD

(51084A/B)	Red/Silver
(51085)	Black/Blue

## 2008 Vulcan® 1600 Classic PARTS LIST

### Fuel Tank(4/4)

ITEM NAME	PART NUMBER	QUANTITY
BRACKET,METER COVER (Ref # 11053)	11053-0275	1
GASKET,FUEL GAUGE (Ref # 11060)	11060-1952	1
COVER,IGNITION SWITCH (Ref # 14091)	14091-0088	1
COVER,METER (Ref # 14091A)	14091-0091	1
PAD,FUEL TANK,CNT,RR (Ref # 39156)	39156-0019	1
PAD,FUEL TANK,RH (Ref # 39156A)	39156-0020	1
PAD,FUEL TANK,LH (Ref # 39156B)	39156-0021	1
PAD,FUEL TANK,CNT,FR (Ref # 39156C)	39156-0022	1
CAP-TANK,FUEL (Ref # 51049)	51049-0003	1
TANK-COMP-FUEL,BLACK/BLUE (Ref # 51085)	51085-5291-19I	1
GAUGE,FUEL (Ref # 52005)	52005-0004	1
WASHER,6.2X11X1.5 (Ref # 92022)	92022-183	3
WASHER,5.1X10X1.0 (Ref # 92022A)	92022-1977	2
COLLAR,L=19.3 (Ref # 92027)	92027-1780	3
CLAMP,TUBE (Ref # 92037)	92037-147	2
CLAMP,HARNESS,L=100 (Ref # 92037A)	92037-1636	1
DAMPER,FUEL TANK (Ref # 92075)	92075-125	2
DAMPER (Ref # 92075A)	92075-1736	3
SEAL,FUEL TANK CAP (Ref # 92093)	92093-1030	1
BOLT,5X12 (Ref # 92151)	92151-1599	4
BOLT,SOCKET,6X10 (Ref # 92153)	92153-1096	3
DAMPER (Ref # 92160)	92160-1162	1
DAMPER (Ref # 92161)	92161-1338	1
CLAMP (Ref # 92171)	92171-1184	2
TUBE,BREATHER (Ref # 92192)	92192-0024	1
TUBE,DRAIN (Ref # 92192A)	92192-0038	1
BOLT-FLANGED,8X30 (Ref # 130)	130H0830	3
BOLT-FLANGED,6X14 (Ref # 130A)	130J0614	2
SCREW-PAN-CROS,5X10 (Ref # 220)	220D0510	2