

2000 Super Sherpa PARTS DIAGRAM

Side Covers/Chain Cover

F2610

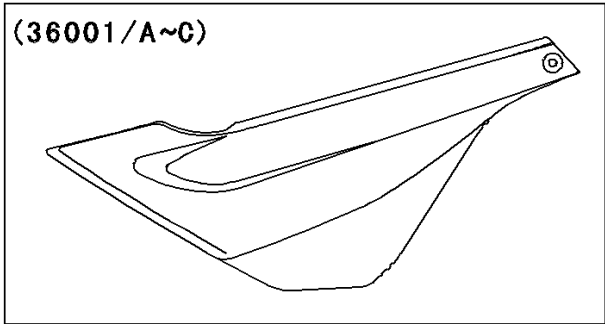
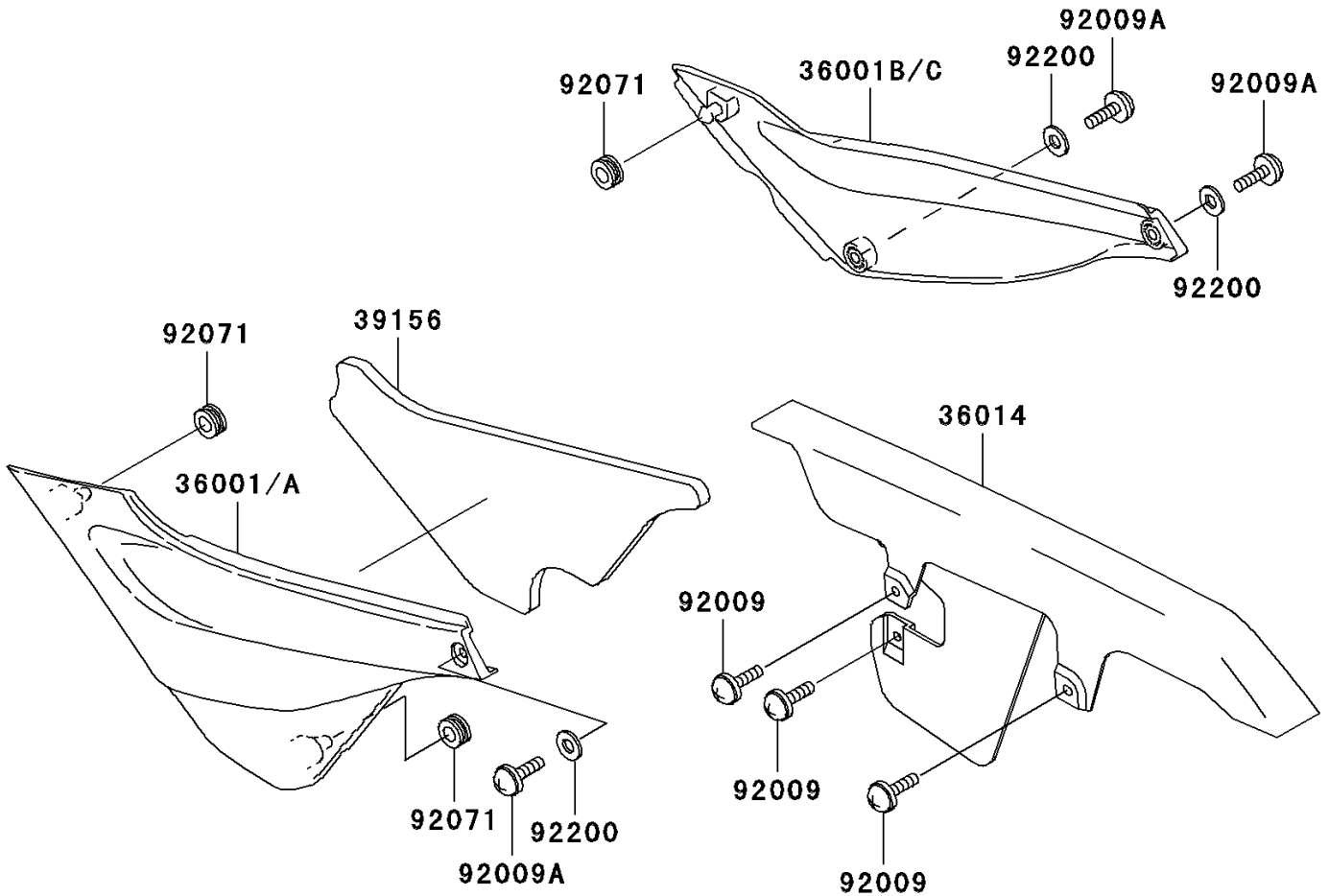

WOD

2000 Super Sherpa PARTS LIST

Side Covers/Chain Cover

| ITEM NAME | PART NUMBER | QUANTITY |
|--------------------------------------|---------------|----------|
| COVER-SIDE,LH,O.GREEN (Ref # 36001A) | 36001-1580-68 | 1 |
| COVER-SIDE,RH,O.GREEN (Ref # 36001C) | 36001-1581-68 | 1 |
| CASE-CHAIN (Ref # 36014) | 36014-1209 | 1 |
| PAD,SIDE COVER,LH (Ref # 39156) | 39156-1580 | 1 |
| SCREW,6X10 (Ref # 92009) | 92009-1661 | 3 |
| SCREW,6X16 (Ref # 92009A) | 92009-1806 | 3 |
| GROMMET (Ref # 92071) | 92071-056 | 3 |
| WASHER,6.5X14X1 (Ref # 92200) | 92200-1388 | 3 |