

1970 Mach III PARTS DIAGRAM

CLUTCH ('73-'75 D/E/F & '76 A8)

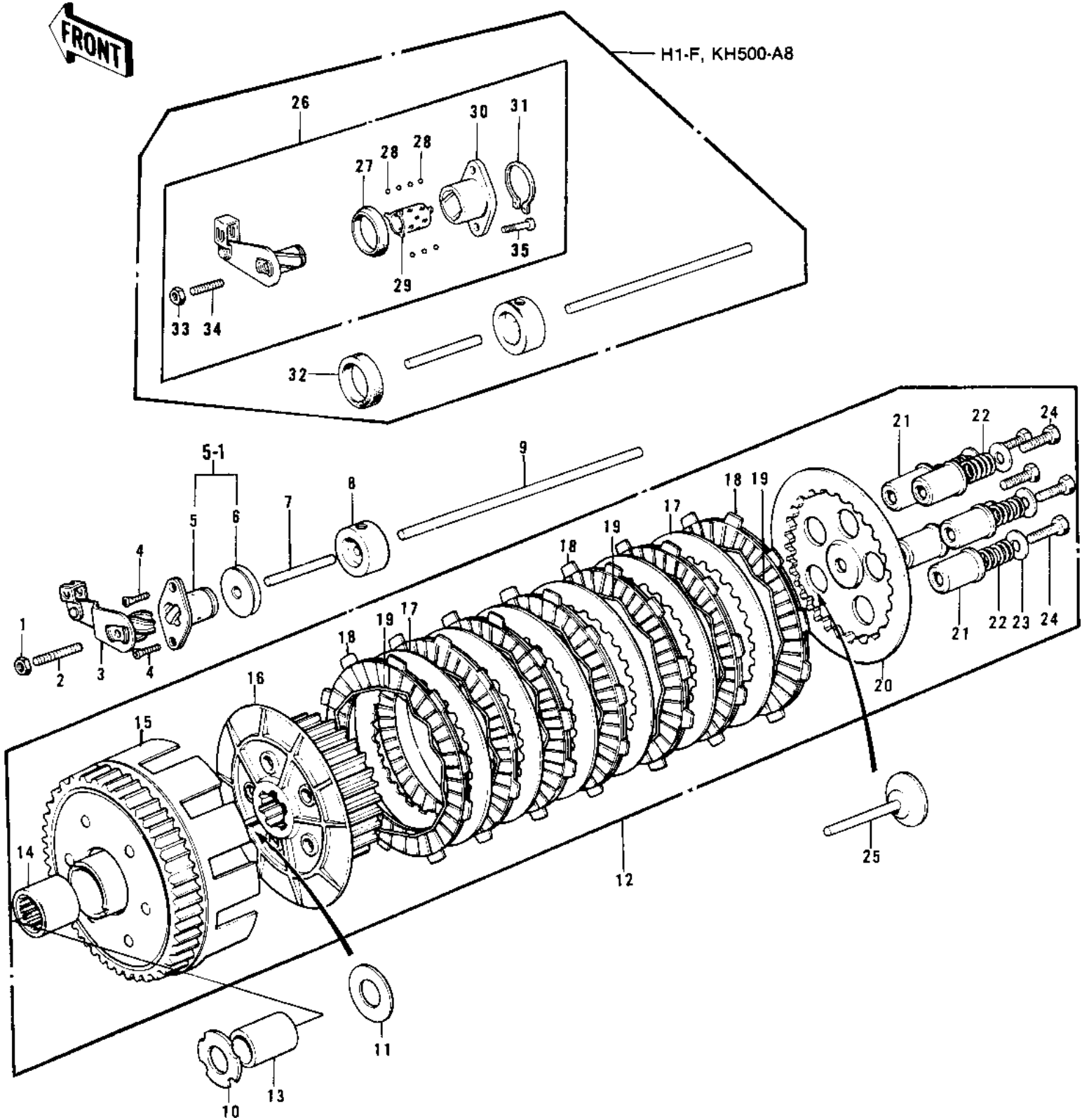

1970 Mach III PARTS LIST

CLUTCH ('73-'75 D/E/F & '76 A8)

ITEM NAME	PART NUMBER	QUANTITY
NUT 6MM (Ref # 1)	311B0600	1
SCREW SLOTTED (Ref # 2)	291Z0625	1
INNER,CLUTCH RELEASE (Ref # 3)	13102-017	1
SCREW CNTSNK HD 6X16 (Ref # 4)	221B0616	2
OUTER,CLUTCH RELEASE (Ref # 5)	13118-008	1
RELEASE ASSY,CLUTCH (Ref # 5-1)	13231-010	1
OIL SEAL SC7317 (Ref # 6)	92050-025	1
ROD CLUTCH PUSH SHORT (Ref # 7)	13116-010	1
BUSH CLUTCH PUSH ROD (Ref # 8)	92028-070	1
ROD CLUTCH PUSH LONG (Ref # 9)	13116-009	1
WASHER THRUST (Ref # 10)	92022-119	1
WASHER TH 25.5X47X2.5 (Ref # 11)	92026-022	1
CLUTCH-ASSY (Ref # 12)	13081-071	1
CLUTCH-ASSY (Ref # 12)	13081-071	1
BUSHING 25X30X34L (Ref # 13)	92028-081	1
BEARING NEEDLE (Ref # 14)	92046-004	1
HOUSING CLUTCH (Ref # 15)	13095-018	1
HUB-CLUTCH (Ref # 16)	13087-030	1
PLATE CLUTCH STEEL (Ref # 17)	13089-013	6
PLATE CLUTCH FRICTION (Ref # 18)	13088-015	7
PLATE CLUTCH FRICTION (Ref # 18)	13088-015	7
PLATE,CLUTCH FRICTION (Ref # 18)	13088-1008	7
RING-CLUTCH STEEL (Ref # 19)	13229-003	7
PLATE-CLUTCH SPRING (Ref # 20)	13187-005	1
GUIDE CLUTCH SPRING (Ref # 21)	13092-005	5
SPRING CLUTCH (Ref # 22)	92081-042	5
HOLDER CL SPG6.5X20X2 (Ref # 23)	13091-009	5
BOLT-UPSET (Ref # 24)	112G0618	5
PUSHER-CLTCH SPRG PLT (Ref # 25)	13116-011	1

1970 Mach III PARTS LIST

CLUTCH ('73-'75 D/E/F & '76 A8)

ITEM NAME	PART NUMBER	QUANTITY
RELEASE ASSY,CLUTCH (Ref # 26)	13231-1001	1
OIL SEAL (Ref # 27)	92056-007	1
BALL,STEEL,1/8" (Ref # 28)	600A0400	11
RETAINER (Ref # 29)	13197-006	1
OUTER,CLUTCH RELEASE (Ref # 30)	13118-015	1
CIRCLIP 15MM (Ref # 31)	480J1500	1
OIL SEAL (Ref # 32)	92050-070	1
NUT 6MM (Ref # 33)	311B0600	1
SCREW SLOTTED (Ref # 34)	291Z0625	1
SCREW PAN HEAD 6X16 (Ref # 35)	220B0616	2