

## 1998 1100 STX PARTS DIAGRAM

Jet Pump

E3191

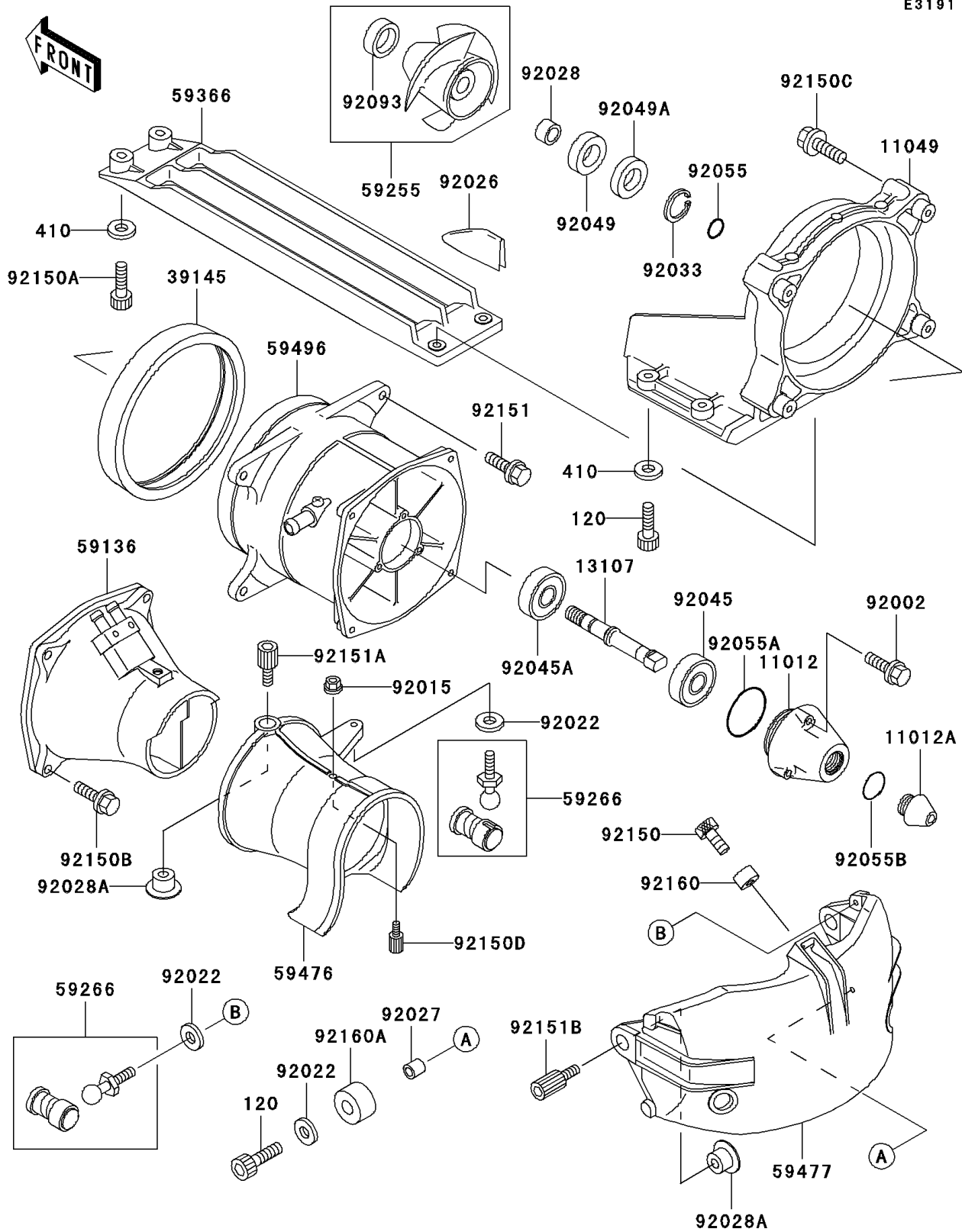

## 1998 1100 STX PARTS LIST

Jet Pump

ITEM NAME	PART NUMBER	QUANTITY
BOLT-SOCKET,6X20 (Ref # 120)	120R0620	1
WASHER-PLAIN-SMALL,6MM (Ref # 410)	410S0600	1
CAP (Ref # 11012)	11012-3785	1
CAP (Ref # 11012A)	11012-3786	1
BRACKET (Ref # 11049)	11049-3759	1
SHAFT,JETPUMP (Ref # 13107)	13107-3752	1
TRIM-SEAL (Ref # 39145)	39145-3742	1
NOZZLE-PUMP (Ref # 59136)	59136-3734	1
IMPELLER-COMP (Ref # 59255)	59255-3711	1
JOINT-BALL (Ref # 59266)	59266-3707	1
GRATE (Ref # 59366)	59366-3712	1
NOZZLE-STRG (Ref # 59476)	59476-3733	1
BUCKET-REVERSE (Ref # 59477)	59477-3707	1
VANE-GUIDE (Ref # 59496)	59496-3718	1
BOLT,6X30 (Ref # 92002)	92002-3726	1
NUT,6MM (Ref # 92015)	92015-3767	1
WASHER (Ref # 92022)	92022-567	1
SPACER (Ref # 92026)	92026-3735	1
COLLAR,6.2X10X10 (Ref # 92027)	92027-3705	1
BUSHING (Ref # 92028)	92028-3756	1
BUSHING (Ref # 92028A)	92028-3757	1
RING-SNAP (Ref # 92033)	92033-3725	1
BEARING-BALL,62022RD (Ref # 92045)	92045-3721	1
BEARING-BALL (Ref # 92045A)	92045-3727	1
SEAL-OIL,SCJ30X50X7 (Ref # 92049)	92049-3720	1
SEAL-OIL,SCY30X50X7 (Ref # 92049A)	92049-3721	1
RING-O,13X1.9 (Ref # 92055)	92055-1021	1
RING-O (Ref # 92055A)	92055-3741	1
RING-O (Ref # 92055B)	92055-3744	1

## 1998 1100 STX PARTS LIST

Jet Pump

ITEM NAME	PART NUMBER	QUANTITY
SEAL, JET PUMP (Ref # 92093)	92093-3739	1
BOLT, SOCKET, 6X10 (Ref # 92150)	92150-3759	1
BOLT, SOCKET, 6X18 (Ref # 92150A)	92150-3775	1
BOLT, 8X35 (Ref # 92150B)	92150-3792	1
BOLT, FLANGED, 8X30 (Ref # 92150C)	92150-3803	1
BOLT (Ref # 92150D)	92150-3808	1
BOLT, 10X30 (Ref # 92151)	92151-3706	1
BOLT (Ref # 92151A)	92151-3710	1
BOLT (Ref # 92151B)	92151-3716	1
DAMPER (Ref # 92160)	92160-3738	1
DAMPER (Ref # 92160A)	92160-3739	1