

1980 KZ1300-A2 PARTS DIAGRAM

GEAR CHANGE MECHANISM

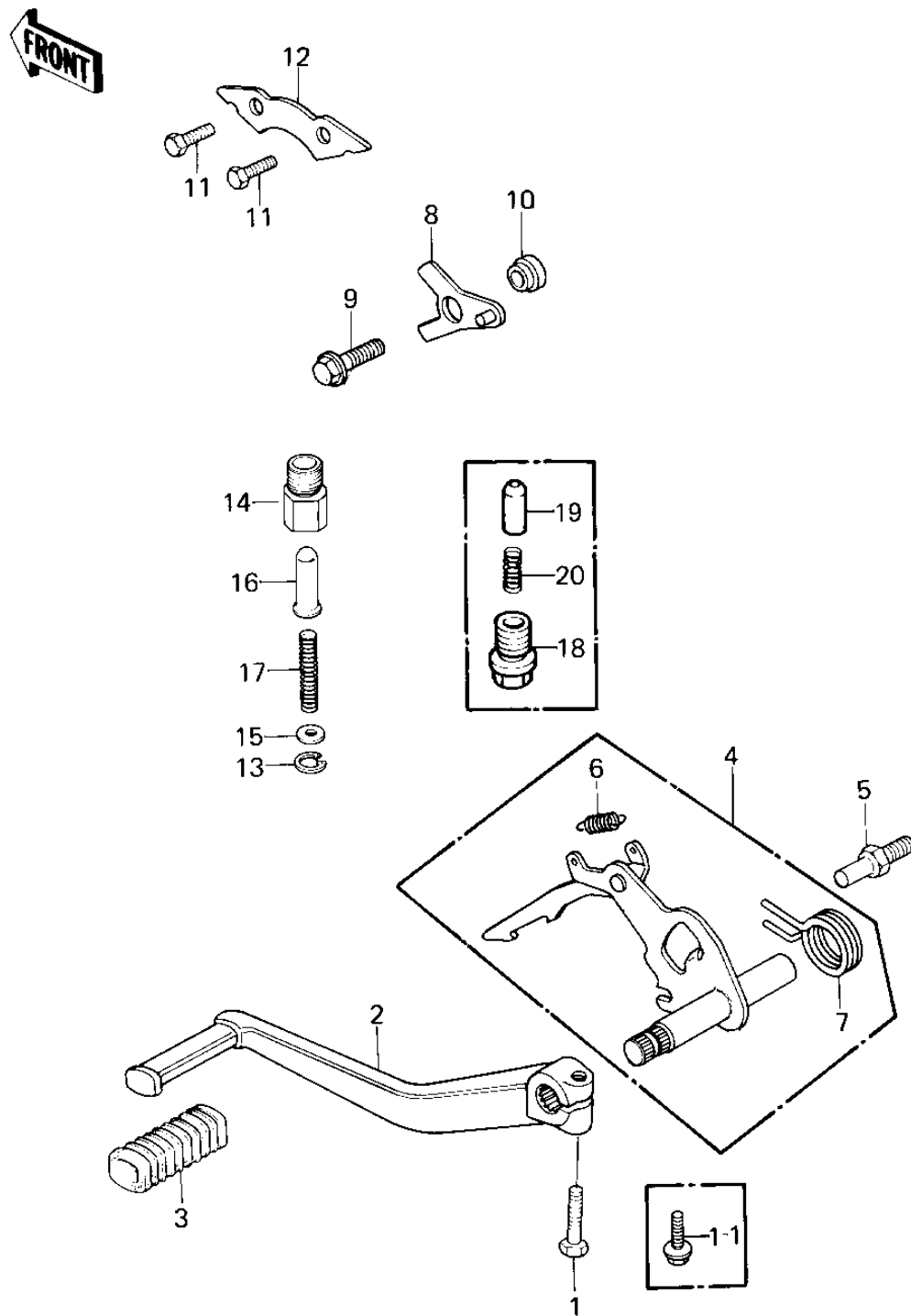

1980 KZ1300-A2 PARTS LIST

GEAR CHANGE MECHANISM

ITEM NAME	PART NUMBER	QUANTITY
BOLT-UPSET (Ref # 1)	112G0625	1
BOLT-FLANGED,6X25 (Ref # 1-1)	130P0625	1
PEDAL,CHANGE (Ref # 2)	13156-1038	2
DAMPER RUBER,CHNG PDL (Ref # 3)	92075-1112	1
DAMPER RUBR GEAR CHNG (Ref # 3)	92075-1175	1
LEVER-COMP-CHANGE SHA (Ref # 4)	13161-1114	1
BOLT,RETURN SPRING (Ref # 5)	92001-1401	2
SPRING-CHANGE LEVER (Ref # 6)	92081-076	1
SPRING,CHG PEDL RTRN (Ref # 7)	92083-028	1
LEVER,CHANGE (Ref # 8)	13168-1034	1
BOLT-FLANGED,8X25 (Ref # 9)	130G0825	2
COLLAR,CHANGE LEVER (Ref # 10)	92027-1139	1
BOLT-UPSET,6X16 (Ref # 11)	112G0616	1
PLATE,POSITION,DRUM (Ref # 12)	14014-1008	1
CIRCLIP, 12MM (Ref # 13)	481J1200	1
BOLT,POSITIONING (Ref # 14)	92001-1134	1
WASHER,4X11.5X1.0 (Ref # 15)	92022-1095	1
PIN,POSITIONING (Ref # 16)	92043-1044	1
SPRING,POSITIONING (Ref # 17)	92081-1094	1
BOLT,10MM (Ref # 18)	92001-131	1
PIN-NEUTRAL POSITION (Ref # 19)	92043-076	1
SPRING (Ref # 20)	92081-112	1