

1979 KZ1000 LTD PARTS DIAGRAM

BATTERY CASE/TOOL CASE (KZ1000-B3)

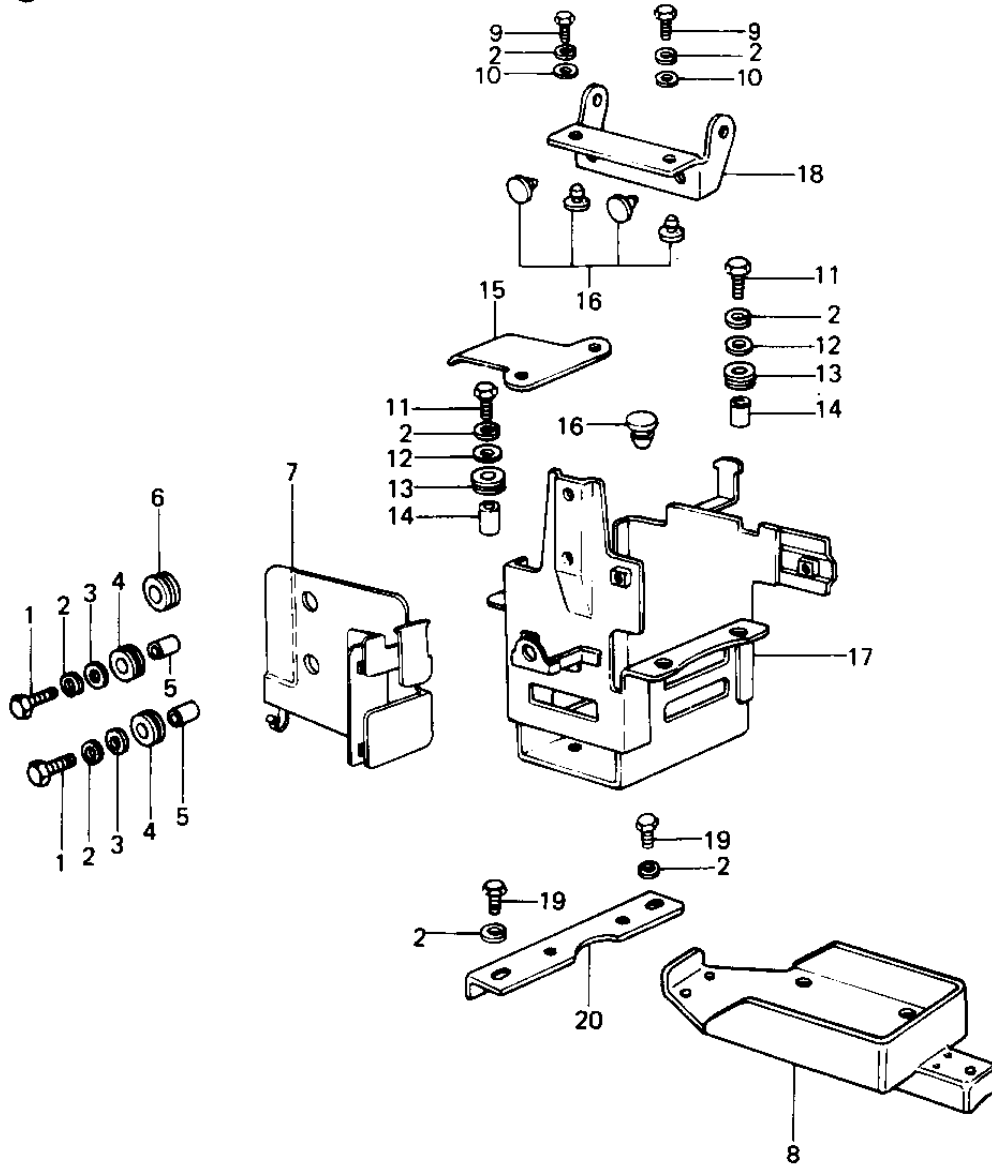

1979 KZ1000 LTD PARTS LIST

BATTERY CASE/TOOL CASE (KZ1000-B3)

ITEM NAME	PART NUMBER	QUANTITY
BOLT-UPSET,6X20 (Ref # 1)	112G0620	2
WASHER SPRING 6MM (Ref # 2)	461F0600	10
WASHER 6.5X22X1.6T (Ref # 3)	92022-237	2
DAMPER RUBBER (Ref # 4)	92075-149	2
COLLAR (Ref # 5)	92027-165	2
DAMPER RUBBER (Ref # 6)	92075-051	1
BRACKET,BASE (Ref # 7)	11034-1261	1
CASE,TOOL (Ref # 8)	32098-1001	1
BOLT-UPSET,6X12 (Ref # 9)	112G0612	2
WASHER PLAIN 6MM (Ref # 10)	411B0600	2
BOLT-UPSET (Ref # 11)	112G0630	4
WASHER,6.5X16X2 (Ref # 12)	92022-1565	4
DAMPER RUBBER,BTT CAS (Ref # 13)	92075-146	4
COLLAR 6.8X10X14.5 (Ref # 14)	92027-156	4
STAY,AIR CLEANER (Ref # 15)	32105-007	1
DAMPER RUBBER (Ref # 16)	92075-078	10
CASE,BATTERY (Ref # 17)	32097-044	1
BAND,BATTERY (Ref # 18)	32100-100	1
BOLT-UPSET,6X16 (Ref # 19)	112G0616	2
PLATE (Ref # 20)	32113-004	1