

1970 Big Horn PARTS DIAGRAM

IGNITION/GENERATOR/REGULATOR

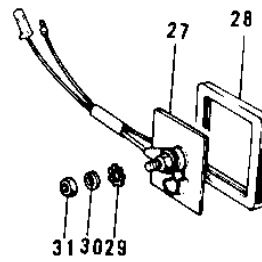
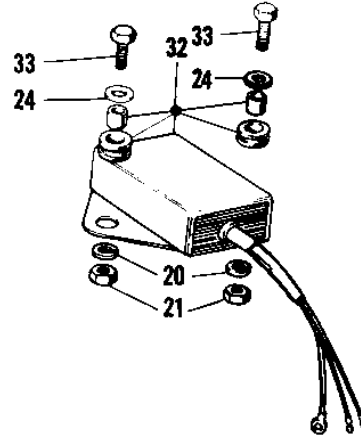
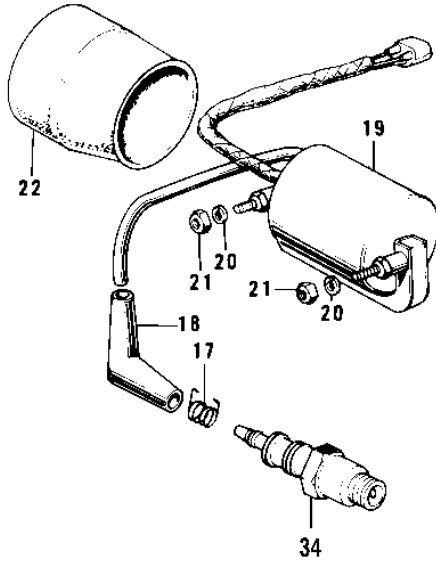

Part No.	d
21050-009	46
21050-010	52

8m/m Thread Holes

Ref. 1

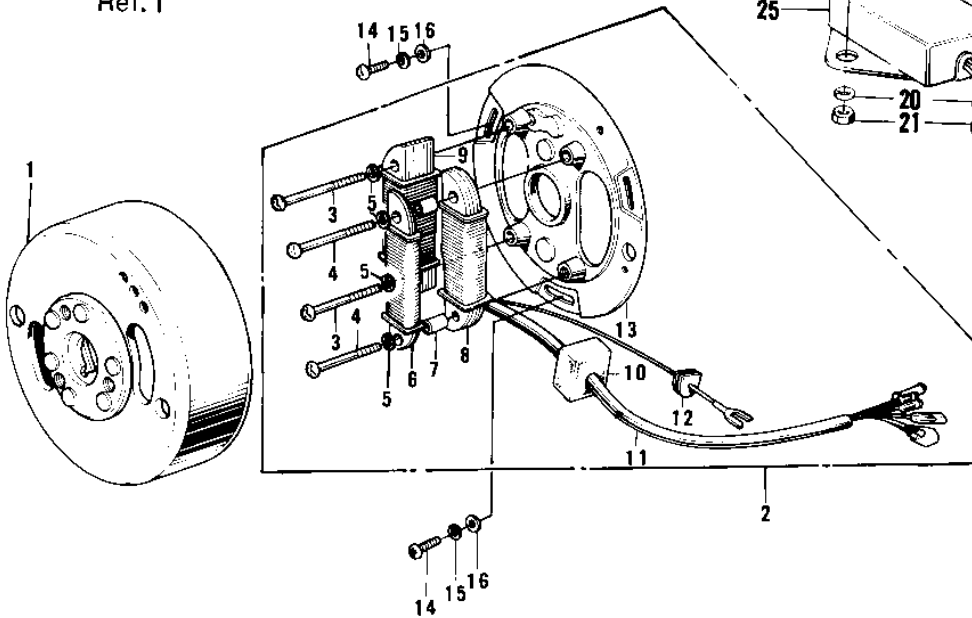
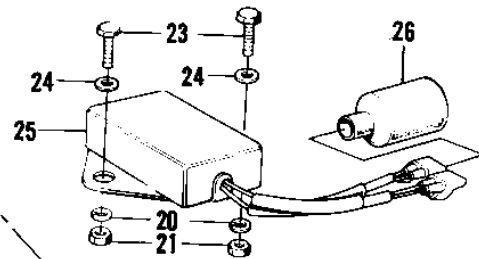

Ref.

10
11
12
13
14
15
16
17
18
19
20
21
22
23
24
25
26
27
28
29
30
31
32
33
34

848-787

1970 Big Horn PARTS LIST

IGNITION/GENERATOR/REGULATOR

ITEM NAME	PART NUMBER	QUANTITY
FLYWEEL (Ref # 1)	21050-015	1
FLYWEEL (Ref # 1)	21050-015	1
FLYWEEL (Ref # 1)	21050-015	1
STATOR (Ref # 2)	21003-011	1
.SCREW PAN HEAD 4X30 (Ref # 3)	220E0430	2
SCREW PAN HEAD 4X30 (Ref # 3)	220E0430	2
.SCREW-PAN HEAD,4X35 (Ref # 4)	220E0435A	2
SCREW-PAN HEAD,4X35 (Ref # 4)	220E0435A	2
.WASHER SPRING 4MM (Ref # 5)	461F0400	4
.COIL-PULSER (Ref # 6)	21157-001	1
.COLLAR (Ref # 7)	21033-002	2
.COIL-PRIMARY (Ref # 8)	21049-011	1
.COIL-LIGHTING (Ref # 9)	21047-012	1
.GROMMET ENG RUBBER A (Ref # 10)	92071-014	1
.WIRING HARNESS-MAGNET (Ref # 11)	21029-020	1
.GROMMET WIRING HARN C (Ref # 12)	21017-005	1
.BASE-MAGNETO (Ref # 13)	21048-013	1
SCREW PAN HEAD 5X20 (Ref # 14)	220B0520	3
WASHER SPRING 5MM (Ref # 15)	461F0500	3
WASHER PLAIN 5MM (Ref # 16)	410B0500	3
SPRING-SPARK PLUG CAP (Ref # 17)	92101-001	1
CAP SPARK PLUG (Ref # 18)	21130-009	1
COIL-IGNITION (Ref # 19)	21121-039	1
WASHER SPRING 6MM (Ref # 20)	461F0600	6
NUT 6MM (Ref # 21)	311B0600	6
RUBBER CAP-COIL (Ref # 22)	92073-016	1
BOLT-UPSET 6X14 (Ref # 23)	112B0614	2
WASHER PLAIN 6MM (Ref # 24)	410B0600	4
IGNITION UNIT (Ref # 25)	21119-013	1

1970 Big Horn PARTS LIST

IGNITION/GENERATOR/REGULATOR

ITEM NAME	PART NUMBER	QUANTITY
IGNITION UNIT (Ref # 25)	21119-013	1
COVER WIRING HARNESS (Ref # 26)	26009-003	1
RECTIFIER (Ref # 27)	21061-5001	1
MAT-RECTIFIER (Ref # 28)	32103-020	1
WASHER-PLAIN (Ref # 29)	92022-163	1
WASHER SPRING 5MM (Ref # 30)	461F0500	1
.NUT,5MM (Ref # 31)	311B0500	1
REGULATOR-VOLTAGE (Ref # 32)	21066-010	1
BOLT-UPSET (Ref # 33)	112G0618	2
SPK PLG L20VMC (Ref # 34)	L20VMC	1
SPK PLG B10H15 (Ref # 34)	B10H15	AL
SPK PLG B10H (Ref # 34)	B10H	AL