

# 1974 Mach I PARTS DIAGRAM

## GEAR CHANGE MECHANISM

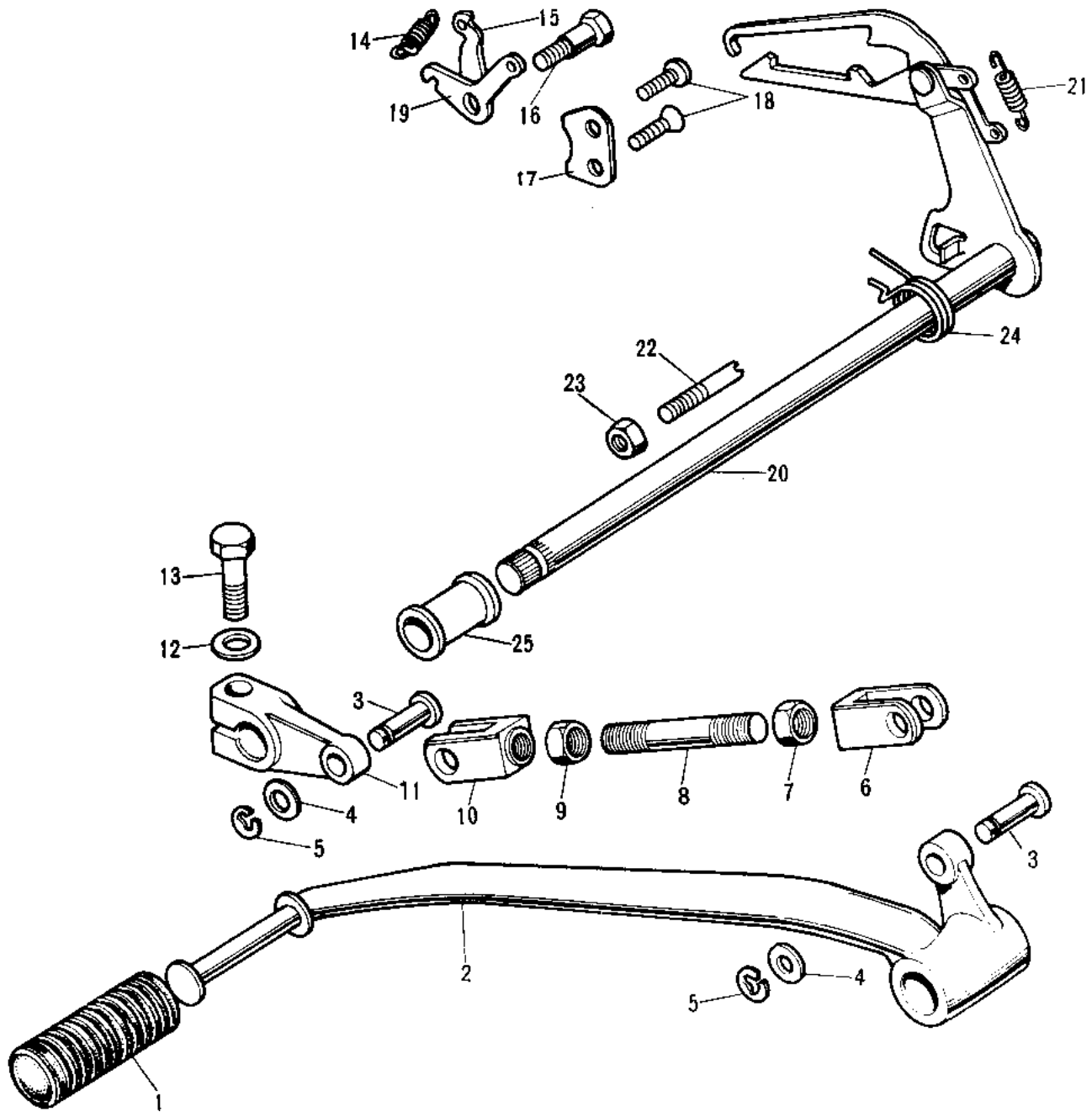

# 1974 Mach I PARTS LIST

## GEAR CHANGE MECHANISM

ITEM NAME	PART NUMBER	QUANTITY
RUBBER CHANGE PEDAL (Ref # 1)	13157-004	
PEDAL ASY,GEAR CHANGE (Ref # 2)	13242-009	
PEDAL ASY,GEAR CHANGE (Ref # 2)	13242-009	
PIN (Ref # 3)	92043-069	
WASHER,PLAIN (Ref # 4)	92022-1028	
CIRCLIP 5MM (Ref # 5)	482K5000	
CONNECTOR,B (Ref # 6)	13159-008	
NUT,8MM (Ref # 7)	92017-010	
ROD (Ref # 8)	92003-074	
NUT,8MM (Ref # 9)	318N0800	
CONNECTOR,A (Ref # 10)	13159-007	
LEVER-GEAR CHANGE (Ref # 11)	13158-007	
WASHER SPRING 8MM (Ref # 12)	461F0800	
BOLT (Ref # 13)	92150-1488	
BOLT-SMALL-UPSET 8X25 (Ref # 13)	115G0825	
SPRING-COIL (Ref # 14)	92081-091	
PLATE-CHNG DRUM LEVER (Ref # 15)	13170-005	
SCREW-PAN HEAD (Ref # 16)	92011-023	
PLATE-DRUM LEV POSTON (Ref # 17)	13169-007	
SCREW CNTSNK HD 6X16 (Ref # 18)	221B0616	
LEVER ASSY-CHNG RETRN (Ref # 19)	13236-002	
LEVER ASSY GEAR CHNG (Ref # 20)	13161-036	
SPRING,CHANGE LEVER (Ref # 21)	92144-1720	
BOLT,RETURN SPRING (Ref # 22)	92001-1401	
NUT 8MM (Ref # 23)	312B0800	
SPRING,TENTION (Ref # 24)	92081-1129	
SPRING,TENTION (Ref # 24)	92081-1129	
DUST SHIELD-CHNG SHT (Ref # 25)	13171-004	