

1977 KE250-B1 PARTS DIAGRAM

OIL PUMP

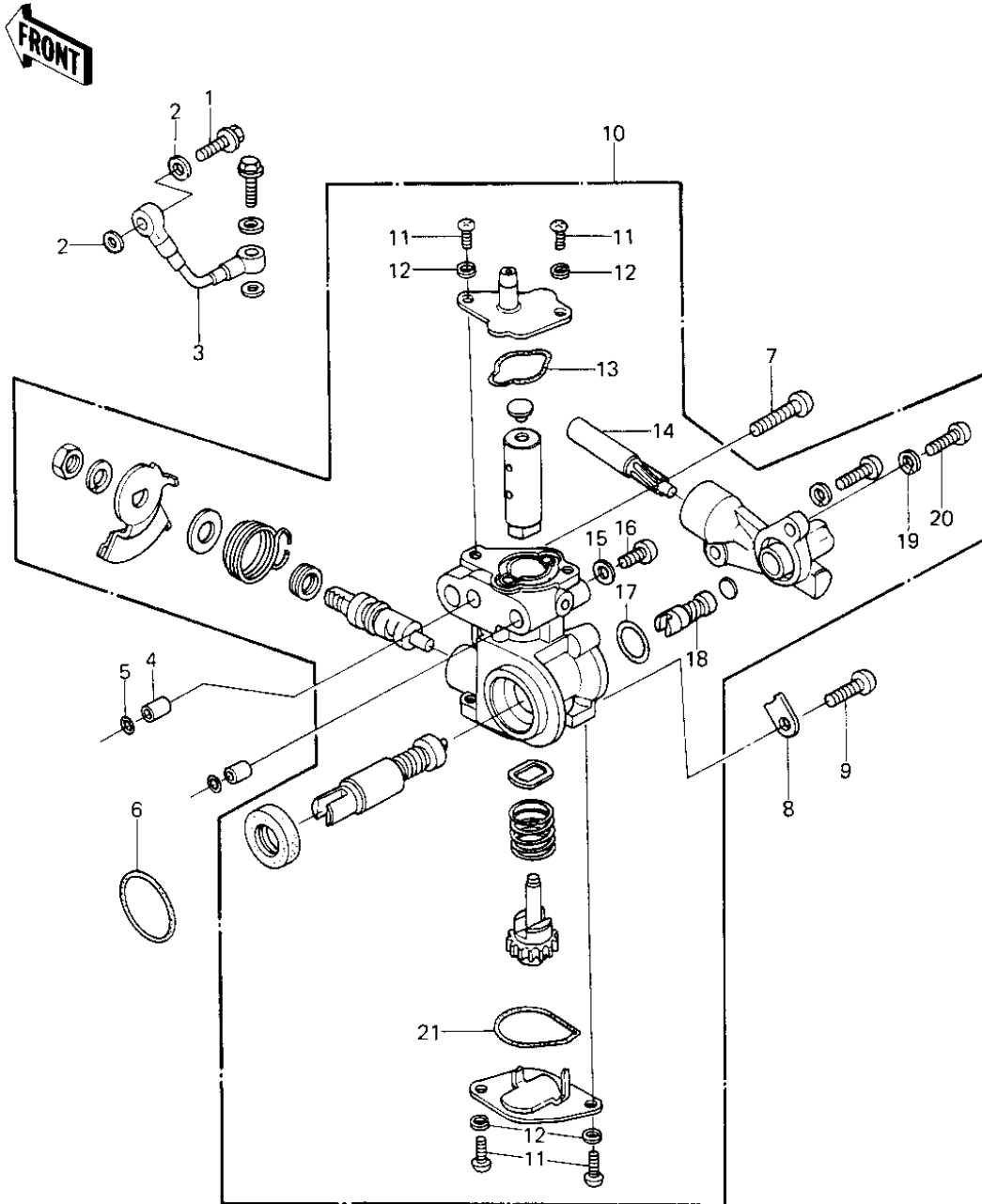

1977 KE250-B1 PARTS LIST

OIL PUMP

ITEM NAME	PART NUMBER	QUANTITY
BOLT-BANJO,6MM (Ref # 1)	92060-013	1
WASHER OIL PUMP BANJO (Ref # 2)	92022-077	1
PIPE,OIL (Ref # 3)	16134-030	1
COLLAR (Ref # 4)	92027-256	1
"O" RING,5MM (Ref # 5)	670B1505	1
"O" RING (Ref # 6)	92055-055	1
SCREW PAN HEAD 5X20 (Ref # 7)	220B0520	1
CLAMP (Ref # 8)	92037-187	1
SCREW PAN HEAD 6X14 (Ref # 9)	220B0614	1
OIL PUMP ASSY (Ref # 10)	16082-1008	3
SCREW PAN HEAD 3X8 (Ref # 11)	220B0308	1
WASHER SPRING 3MM (Ref # 12)	461F0300	1
"O" RING,OIL PUMP,UPP (Ref # 13)	92055-1016	1
GEAR,TACHOMETER (Ref # 14)	41060-1008	1
WASHER,AIR VENT (Ref # 15)	92022-1025	1
"O" RING,TACHOMTR CAS (Ref # 17)	92055-1017	1
GEAR,WORM TACHOMETER (Ref # 18)	41060-1007	1
WASHER SPRING 4MM (Ref # 19)	461F0400	1
SCREW PAN HEAD 4X10 (Ref # 20)	220B0410	1
"O" RING,OIL PUMP LOW (Ref # 21)	92055-1015	1