

1983 Duckster PARTS DIAGRAM

CHAIN CASE

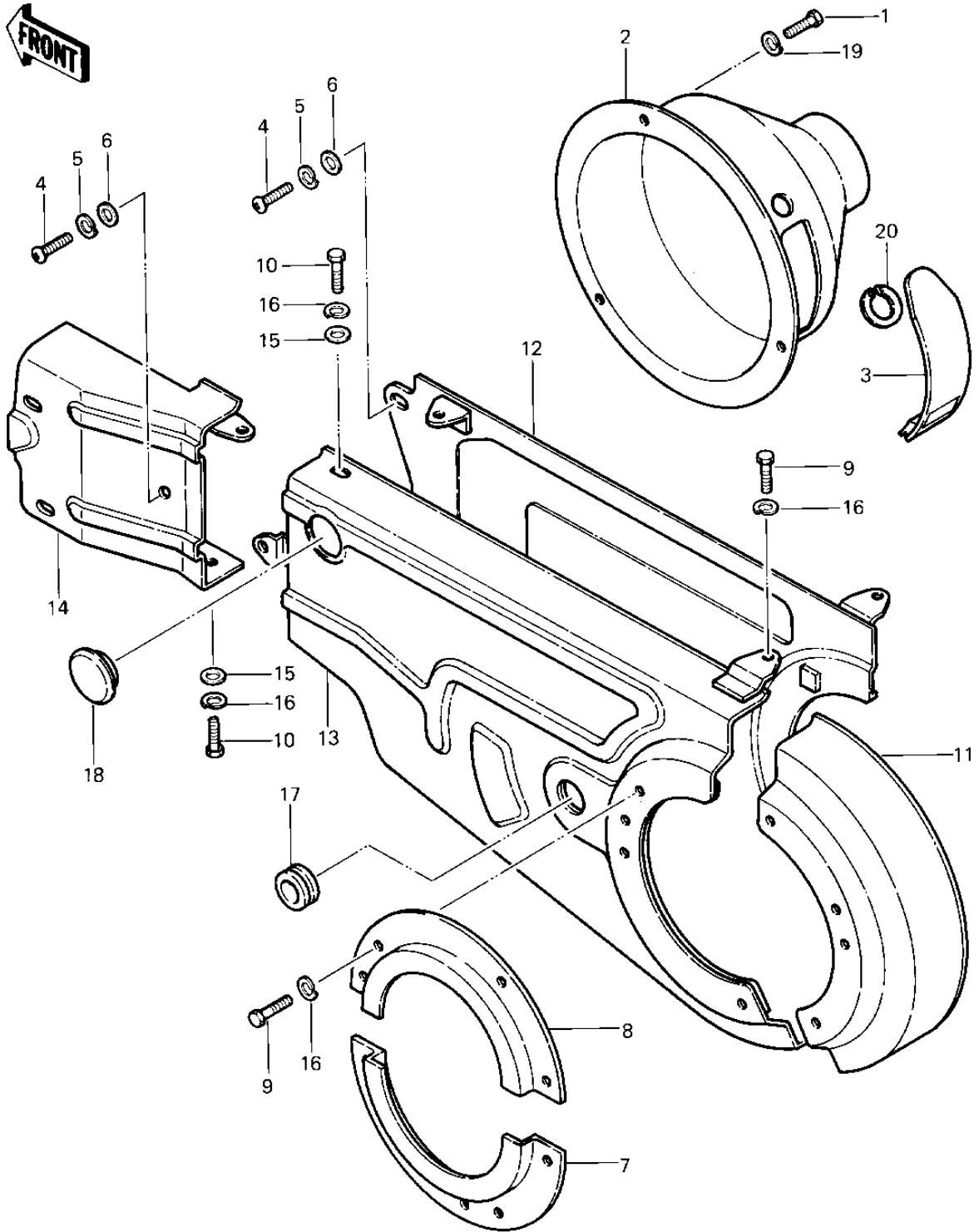

1983 Duckster PARTS LIST

CHAIN CASE

ITEM NAME	PART NUMBER	QUANTITY
BOLT-UPSET,6X12 (Ref # 1)	112G0612	3
COVER,DIFFERENTIAL (Ref # 2)	14025-4009	1
COVER,DIFFERENTIAL (Ref # 3)	14025-4010	1
SCREW PAN HEAD 6X12 (Ref # 4)	220B0612	5
WASHER SPRING 6MM (Ref # 5)	461F0600	5
WASHER PLAIN 6MM (Ref # 6)	410B0600	5
BRACKET,SMALL (Ref # 7)	11036-1455	1
BRACKET,LARGE (Ref # 8)	11036-1454	1
BOLT-UPSET,6X12 (Ref # 9)	112G0612	11
BOLT-UPSET 6X14 (Ref # 10)	112B0614	2
CASE-CHAIN,RR (Ref # 11)	36014-1059	1
CASE-CHAIN,INNER (Ref # 12)	36014-1041	1
CASE-CHAIN,FR (Ref # 13)	36014-1060	1
CASE-CHAIN,FR (Ref # 14)	36014-1049	1
WASHER PLAIN 6MM (Ref # 15)	410B0600	2
WASHER SPRING 6MM (Ref # 16)	461F0600	13
GROMMET HARNESS 22MM (Ref # 17)	92071-012	1
PLUG CHAIN CASE (Ref # 18)	92074-004	1
WASHER SPRING 6MM (Ref # 19)	461F0600	3
CIRCLIP, 20MM (Ref # 20)	480J2000	1