

1983 Duckster PARTS DIAGRAM

OIL PUMP/OIL FILTER ('83 KLT200-A4/A4A)

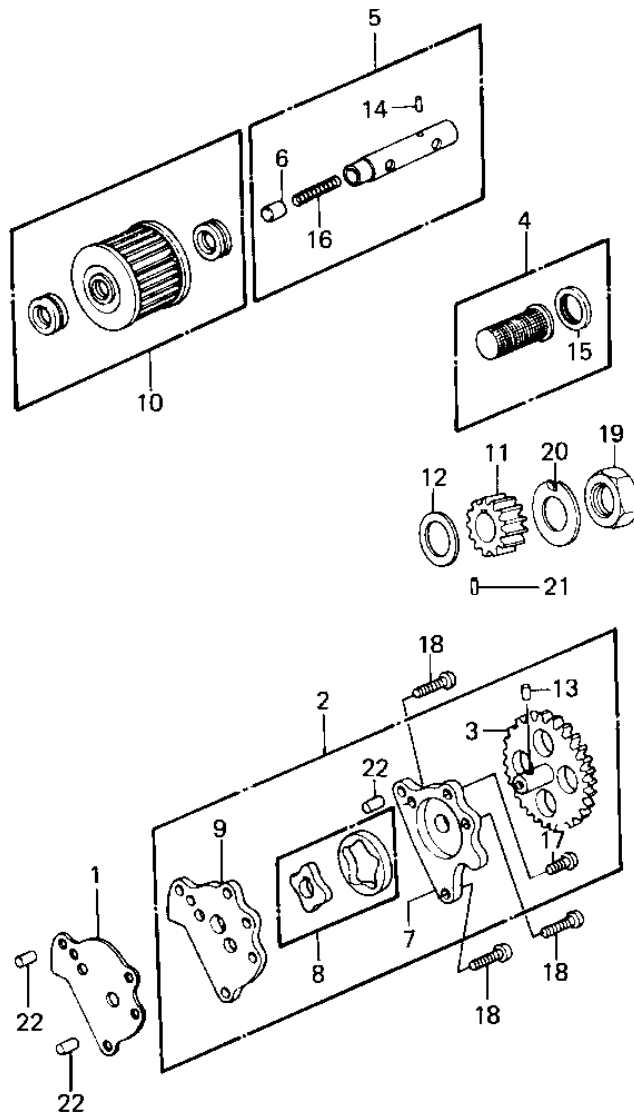

E1710-0003



1983 Duckster PARTS LIST

OIL PUMP/OIL FILTER ('83 KLT200-A4/A4A)

ITEM NAME	PART NUMBER	QUANTITY
GASKET,OIL PUMP (Ref # 1)	11060-1115	1
PUMP ASSY OIL (Ref # 2)	16082-1015	1
GEAR,OIL PUMP (Ref # 3)	16085-026	1
STRAINER ASSY,OIL (Ref # 4)	16097-1001	1
BOLT ASSY,OIL FILTER (Ref # 5)	16156-002	1
PISTON (Ref # 6)	92136-002	1
COVER OIL PUMP (Ref # 7)	16142-1006	1
ROTOR OIL PUMP (Ref # 8)	16154-1008	1
BODY,OIL PUMP (Ref # 9)	16141-006	1
FILTER,OIL (Ref # 10)	16099-004	1
GEAR,OIL PUMP (Ref # 11)	16084-018	1
WASHER-THRUST (Ref # 12)	92022-170	1
PIN,DOWEL (Ref # 13)	92042-041	1
SPRING PIN (Ref # 14)	92043-123	1
GROMMET,OIL STRAINER (Ref # 15)	92071-100	1
SPRING,PISTON (Ref # 16)	92081-043	1
SCREW PAN HEAD 6X16 (Ref # 17)	220B0616	1
SCREW PAN HEAD 6X25 (Ref # 18)	220B0625	3
NUT 16MM (Ref # 19)	315B1600	1
WASHER,LOCK,16M/M (Ref # 20)	420B1611	1
PIN DOWEL 3X12 (Ref # 21)	551A0312	1
PIN,DOWEL,6X8 (Ref # 22)	551A0608	3