

## 1977 KE175 PARTS DIAGRAM

FRONT FORK

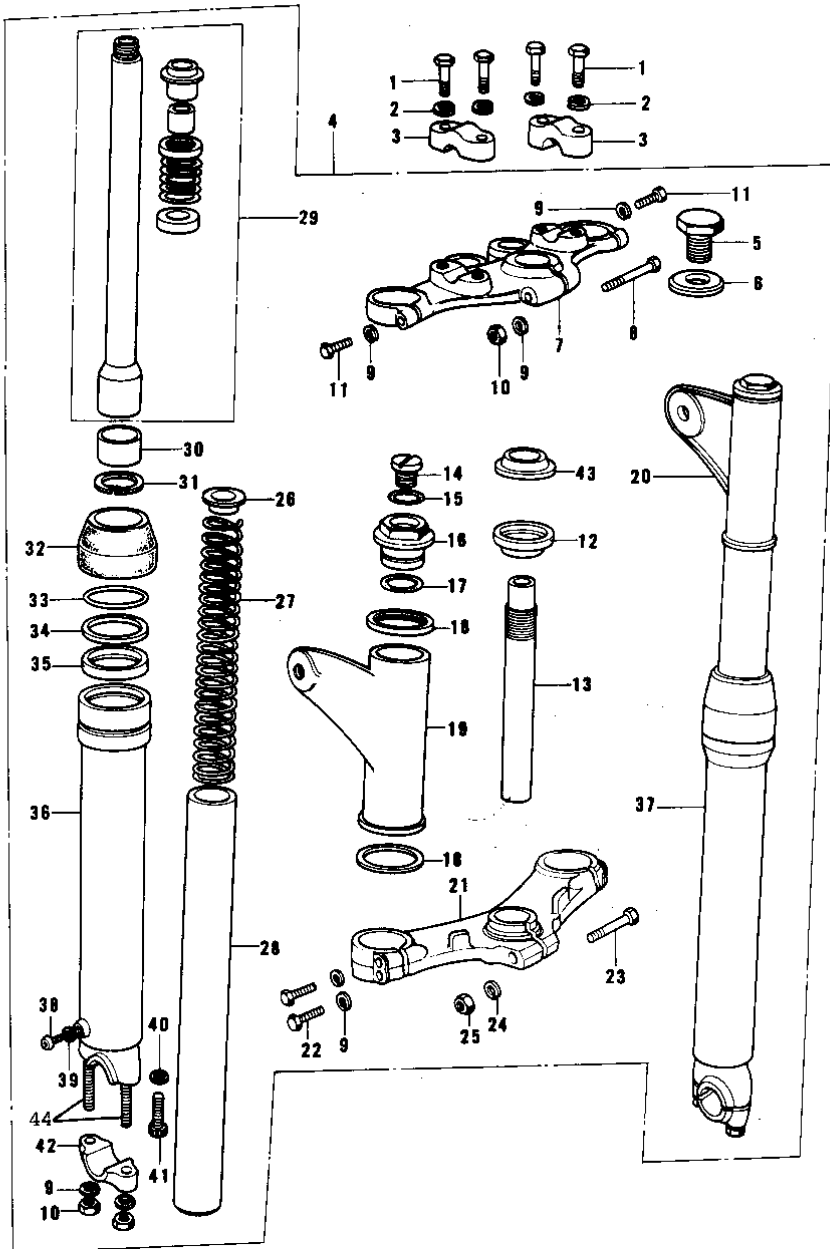

## 1977 KE175 PARTS LIST

### FRONT FORK

ITEM NAME	PART NUMBER	QUANTITY
BOLT 8X38 (Ref # 1)	92001-1405	1
WASHER SPRING 8MM (Ref # 2)	461F0800	2
HOLDER,HANDLEBAR (Ref # 3)	46012-014	1
FORK-FRONT (Ref # 4)	44001-171	1
BOLT STRNG STEM HEAD (Ref # 5)	44041-007	1
WASHER STRNG STEM HD (Ref # 6)	44043-016	1
HEAD,STEERING STEM (Ref # 7)	44039-068	1
BOLT,FORK TOP (Ref # 8)	44041-065	1
NUT,8MM (Ref # 10)	311B0800	1
BOLT-STEERING STEM HD (Ref # 11)	44041-044	1
DUST SHIELD-STRNG STM (Ref # 12)	44010-020	1
SHAFT,STEERING STEM (Ref # 13)	44052-011	1
SCREW, TOP BOLT (Ref # 14)	44041-082	1
"O" RING (Ref # 15)	44046-024	1
BOLT,FORK TOP (Ref # 16)	44032-013	1
'O' RING FORK FIT BLT (Ref # 17)	44046-013	1
GASKET,FORK COVER (Ref # 18)	44045-055	1
COVER,L.H FORK (Ref # 19)	44033-075	1
COVER,R.H FORK (Ref # 20)	44034-075	1
STEM,STEERING (Ref # 21)	44038-010	1
BOLT HEX HEAD 8X35 (Ref # 22)	110N0835	1
BOLT-STEERING STEM HD (Ref # 23)	44041-042	1
WASHER SPRING 10MM (Ref # 24)	461F1000	1
NUT (10MM) (Ref # 25)	311B1000	1
GUIDE,FORK SPRING (Ref # 26)	44028-038	1
SPRING,FORK (Ref # 27)	44026-069	1
TUBE,FORK INNER (Ref # 28)	44013-053	1
CYLINDER-FORK (Ref # 29)	44022-036	1
PISTON,FORK (Ref # 30)	44018-010	1

## 1977 KE175 PARTS LIST

### FRONT FORK

ITEM NAME	PART NUMBER	QUANTITY
CIRCLIP,26MM (Ref # 31)	481J2600	1
DUST SHIELD (Ref # 32)	44010-033	1
CIRCLIP,FORK OUT TUB (Ref # 33)	44044-022	1
WASHER (Ref # 34)	44043-059	1
OIL SEAL (Ref # 35)	44009-025	1
TUBE,LH,FORK OUTER (Ref # 36)	44005-062	1
TUBE,RH,FORK OUTER (Ref # 37)	44006-060	1
SCREW PAN HEAD 4X8 (Ref # 38)	220B0408	1
GASKET FORK DRAIN PLG (Ref # 39)	44045-002	1
GASKET,FORK CYLINDER (Ref # 40)	44045-057	1
BOLT-FORK CYLINDER (Ref # 41)	44041-040	1
HOLDER,FORK AXLE (Ref # 42)	44063-013	1
CONE STERNG BERG LOW (Ref # 43)	92047-010	1
STUD 8X30 (Ref # 44)	172G0830	1