

## K53021-099 DRIFTER SADDLEBAG SUPPORT LOOPS MOUNTING INSTRUCTIONS

Please read all instructions before starting installation.

It is recommended that a qualified mechanic or technician install this accessory.

### Supplied Hardware

Number	Description	Qty.
1	1-1/2" x 5/16" Hex Bolts	4
2	5/16" Flat Washers	4
3	Support Loop (R & L)	2

**NOTE:** Saddlebags come un-drilled to accommodate various motorcycles, accessories and aftermarket products. Determine proper placement by following the directions below.

1. Install the right saddlebag support loop temporarily to the mounting struts with the supplied hardware. Loops should slant rearward (Fig. 1) and outward (Fig. 2).
2. Hold the right saddlebag up to the mounting assembly. Find a suitable position by allowing at least 2" of clearance from the exhaust system and adequate clearance of any other parts or accessories (Fig. 2).

**NOTE:** When the stock 2-up seat and grab handle are used, there is often no way to eliminate a slight interference between the saddlebag lid and passenger grab handle when the saddlebag is opened.

3. Mark the back of the saddlebag where the support loop bolts are touching the saddlebag.
4. Drill the right saddlebag in the marked positions with a 3/8" drill bit.
5. Place the left and right saddlebags back to back. Mark the left saddlebag drilling positions through the inside of the right saddlebag onto the back of the left saddlebag.
6. Drill the left saddlebag using a 3/8" drill bit in the positions marked.
7. Install the saddlebags as shown in Fig. 2.

**NOTE:** These saddlebags have been tested and approved on the Drifter for speeds of up to 87 miles per hour. This speed should not be exceeded when these accessories are installed.

### FIGURE 1 – SIDE VIEW OF SUPPORT LOOP

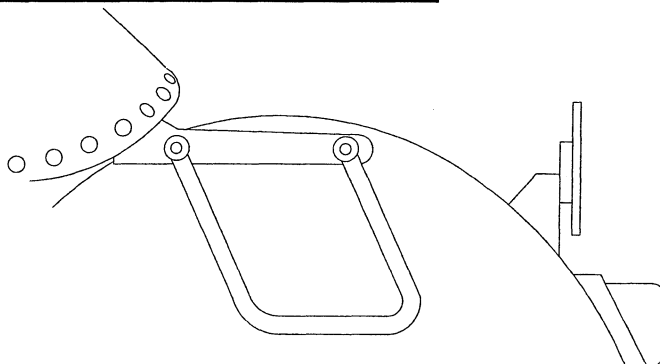

**FIGURE 2 – VIEW FROM REAR OF MOTORCYCLE**

